



Dealer Network

McLaren London	+44 203 151 0030
McLaren Birmingham	+44 121 457 6609
McLaren Manchester	+44 742 562 4301
McLaren Paris	+33 612 172 600
McLaren Monaco	+33 640 629 132
McLaren Hamburg	+49 405 910 0100
McLaren Düsseldorf	+49 211 9446 1762
McLaren München	+49 894 4455 1144
McLaren Frankfurt	+49 694 269 4060
McLaren Stuttgart	+49 703 1309 4670
McLaren Vienna	+43 664 807 413 223
McLaren Milan	+39 333 705 3076
McLaren Brussels	+32 470 595 959
McLaren Geneva	+41 799 191 212
McLaren Zürich	+41 432 114 448
McLaren Marbella	+34 637 446 393

McLaren Stockholm	+46 40 437 000
McLaren Utrecht	+31 302 212 121
McLaren Client Services	UK business hours: +44 148 326 1500 client.services@mclaren.com

In the unlikely event that you are unable to obtain assistance using the appropriate number(s) listed, you can call the appropriate European assistance number:

The McLaren Assistance number in the UK is Freephone: 0800 975 8285.

The McLaren Assistance number in Europe is Freephone: 00800 4886 4887.



NOTE: If you have problems contacting us on the Freephone number while in Europe please call on: +33 472 172 519.

Please be aware that standard charges for this call will apply.

For further information on contacting McLaren dealers, please refer to your Service and Warranty book.



BEFORE YOU DRIVE.....	1.1
DRIVING CONTROLS	2.1
INSTRUMENTS.....	3.1
COMFORT AND CONVENIENCE	4.1
MAINTAINING YOUR McLAREN.....	5.1
VEHICLE DATA AND GLOSSARY	6.1
INDEX	7.1

Introduction

Please read this information to familiarise yourself with your McLaren and its features before you drive. This provides the necessary information for you to get the optimum benefit and enjoyment from your McLaren.

This publication contains information and images for both Coupe and Spider models where applicable.

The documents supplied with your McLaren are an integral part of the vehicle. Ensure that you pass them onto the new owner if you sell the vehicle.

The information is divided into specific sections, to assist in finding the particular information you require:

Before you drive

Details the settings you need to make in the cockpit to ensure you are fully prepared and have safe and easy access to all controls before driving.

Driving Controls

This section contains detailed information regarding the equipment and driving controls fitted to your McLaren and how to use those controls to best effect during a journey.

Instruments

This section contains information on the instrument cluster, including information of how to view and change vehicle settings.

Comfort and Convenience

Contains information on those systems and features which make the cockpit a pleasant environment in which to spend time.

Maintaining your McLaren

Information on maintaining your McLaren is here. Also included is advice on using your McLaren in winter weather and if you choose to drive your vehicle abroad, what to do if something should go wrong and how to manage any possible problems which arise as a result. Information on fuses, lights and what to do if you experience a puncture.

Data and Technical glossary

Refer to this section when you need information regarding the fluids and quantities that are required for the various systems on your McLaren, or when you need to know a specific piece of data relating to your McLaren or its performance.

The Technical glossary contains a brief explanation of some of the more complex systems fitted to your McLaren. Your McLaren Retailer will be able to assist should you need more information.

Index

The table of contents and the index will help you find information quickly, when you need it.

Information about this document

McLaren is constantly updating its vehicles to meet and exceed the latest technologies. McLaren therefore reserves the right to introduce changes in design, equipment and technical features at any time.

© McLaren Automotive Limited.

This publication must not be reproduced, translated or reprinted, in whole or in part, without written permission from McLaren Automotive Ltd.

The equipment fitted to your McLaren may vary from that shown depending on vehicle and market specification. Your McLaren may vary from the images shown depending on vehicle and market specification

This vehicle may be covered by patents. See cars.mclaren.com/patents

Printed in United Kingdom, 11Q0839CP.01

Electronic User Manual

If your vehicle is fitted with electronic user manual the owner's handbook and IRIS user guide are available on the IRIS screen.

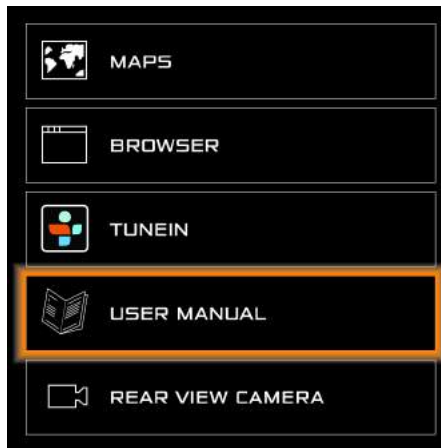

To access the manuals, navigate to the APPS screen and select USER MANUAL. This will launch the user manual application.

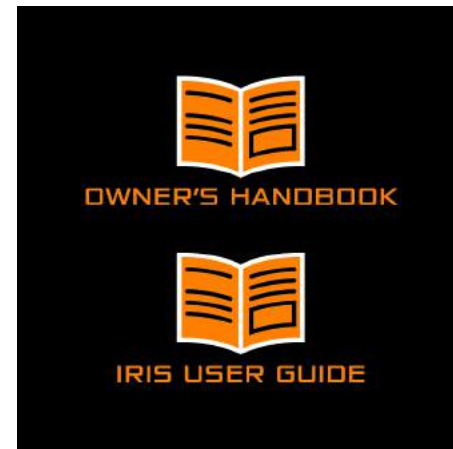

Select the OWNER'S HANDBOOK or IRIS USER GUIDE to access the information.

CONTENTS

INTRODUCTION

BEFORE YOU DRIVE

DRIVING CONTROLS

INSTRUMENTS

COMFORT AND CONVENIENCE

MAINTAINING YOUR MCLAREN

VEHICLE DATA AND GLOSSARY

INDEX

Select the chapter required, this will take you to the chapter contents page.

 **NOTE:** Selecting the *INDEX* from the main contents page will navigate you to an alphabetical index of topics covered in Owner's handbook. The *INDEX* is not available for IRIS user guide.

DRIVING CONTROLS

STARTING AND DRIVING

SEAMLESS SHIFT GEARBOX

HANDLING AND POWERTRAIN CONTROLS

DRIVING SAFETY SYSTEMS

CRUISE CONTROL

ACTIVE SPEED LIMITER (ASL)

RUNNING IN

REFUELLING

WINTER DRIVING

Select the section required from the chapter contents to access the required information.

When the section is displayed, the screen can be scrolled by touching the screen and dragging a finger up or down as required. Hotspot links are identified by orange underlined text. Selecting a hotspot link will navigate you to the information identified in the text.



The Library icon appears at the top of the main contents page. Selecting the library button will return you to the library where all available owner information can be accessed.



The Home icon appears at the top and the bottom of each page. Selecting the home button will return you to the main contents page.





The icons at the bottom of the screen (end of the section) can be used to navigate to the previous or next section as required.

Symbols

You will find the following symbols in this Owner's handbook. These symbols are intended to give you an instant visual message on what type of information is being displayed.

Warnings

	A warning draws your attention to activities that could cause injury or death.
Notes	
	Notes draw your attention to activities that contain possible risks to your McLaren, provide advice that you may find useful, or give additional information regarding a particular subject.
Optional equipment	
*	Optional equipment is identified with an asterisk. The equipment fitted to your McLaren may vary from that shown depending on vehicle specification.
Environmental note	
	Environmental notes give you tips on minimising the impact of you and your vehicle on the environment.

Operating safety



WARNING: The electronic systems fitted to your McLaren interact with each other. Tampering with these systems could cause malfunctions in other interconnected systems. Such faults could seriously endanger the operational safety of your McLaren and your own safety.

Additional work or modifications made to the vehicle, which have been carried out incorrectly can also affect its operating safety.

Vehicle use

Observe the following when using your McLaren:

- the safety notes throughout this information
- road traffic laws and regulations



WARNING: There are various warning labels attached to your McLaren.

These are intended to make you and others aware of various risks. Do not remove any warning labels from the vehicle.

If you remove these warning labels, you or others may not then be aware of dangers, which may result in an injury.

OPENING AND CLOSING

General.....	1.2
Opening a door.....	1.5
Locking a door.....	1.6
Mislock.....	1.7
Individual settings.....	1.8
Locking and unlocking from inside.....	1.8
Opening a door from inside.....	1.9
Closing a door.....	1.10
Automatic locking.....	1.10
Engine cover.....	1.11
Luggage compartment.....	1.12
Retractable Roof - Spider models.....	1.14
Backlight - Spider models.....	1.17
Tonneau Cover - Spider models.....	1.19

STOWING LUGGAGE

Stowage Luggage - Spider models.....	1.21
--------------------------------------	------

ANTI-THEFT SYSTEM

Alarm system.....	1.24
Immobiliser.....	1.24
Tow-away protection.....	1.25
Interior motion sensor*.....	1.26

SEATS

Safety.....	1.27
Manual seats.....	1.27
Racing seats*.....	1.28
Electric seats*.....	1.29

STEERING WHEEL AND STEERING COLUMN

Manual steering wheel adjustment.....	1.34
Electric steering wheel adjustment*.....	1.35
Horn.....	1.36

OCCUPANT SAFETY

Seat belts.....	1.37
Supplementary Restraint System.....	1.39
Child passengers.....	1.44

MIRRORS

Safety.....	1.46
Interior mirror.....	1.46
Exterior mirrors.....	1.46

LIGHTING

Exterior lighting.....	1.48
Light switch.....	1.49
Main beam headlamps.....	1.50
Daytime running lamps.....	1.51
Rear fog lamp.....	1.51
Direction indicators.....	1.52
Hazard warning lamps.....	1.52
Parking lights.....	1.53

WASHERS AND WIPER

Windscreen wiper.....	1.54
-----------------------	------

VEHICLE LIFT*

Vehicle Lift Operation.....	1.56
-----------------------------	------

BEFORE YOU DRIVE

OPENING AND CLOSING

General

The vehicle can be unlocked or locked either by using the keyless entry feature, or by pressing the appropriate button on the key fob.

The keyless entry feature requires the key to be within 1.5 metres (5 feet) of the door sensors.

For your convenience, provided that the engine is not running, the car can be locked irrespective of the electrical status, see Vehicle electrical status, page 2.2.

Keyless entry

Keyless entry allows the driver to unlock and disarm the vehicle by simply opening the door when the key fob is within 1.5 metres (5 feet) of the door sensors. The key fob needs only to be on the driver's person or in a non-metallic container such as a bag. It does not need to be exposed or handled.

Four sensors detect where the key fob is around the vehicle.

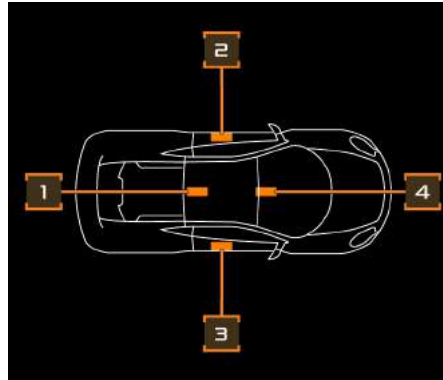

1. In vehicle sensor
2. Left-hand door sensor
3. Right-hand door sensor
4. Cup holder sensor

Key fob entry

Your McLaren includes two remote control key fobs. The key fob allows you to remotely lock and unlock the vehicle.

i *NOTE: To prevent theft, only use the key fob in the immediate vicinity of the vehicle.*

The key fob locks and unlocks the following:

- the doors (including fuel filler flap)
- the luggage compartment

BEFORE YOU DRIVE

OPENING AND CLOSING



To unlock the vehicle, using the key fob, press the unlock button. The front, rear and side direction indicators flash twice and the anti-theft alarm system is deactivated.

The unlock button operation changes depending whether the DRIVER or BOTH is selected in the vehicle settings, see Door Unlock, page 3.14.

i *NOTE: If the vehicle is dirty or wet, is advisable to open the doors using the key fob.*

A quick double press of the unlock button will unlatch the driver's door. A long press and hold on the unlock button will unlatch the passenger's door.

! **WARNING: The key fob allows the engine to be started and is also used to activate other features on the vehicle.**

Take the key fob with you, every time you leave the vehicle.

i *NOTE: Do not expose the key fob to high levels of electromagnetic radiation. Doing so may cause it to function incorrectly. For example close proximity to laptops, tablets, personal media players, or mobile phones.*

Unlock Button	Outcome
Single Press	If BOTH is selected, a single press of the button unlocks both doors. If DRIVER is selected, a single press of the button unlocks the driver's door. A second press (after a pause) unlocks the passenger's door.
Double Press	If BOTH is selected, a double press of the button unlocks both doors and unlatches the driver's door. If DRIVER is selected, a double press of the button will unlock and unlatch the driver's door only.
Long Press	A long press of the button will unlock both doors and unlatch the passenger's door.

BEFORE YOU DRIVE

OPENING AND CLOSING

Stowing the key fob

For security, it is recommended that the key fob stays on your person when you are in the car. If, however, you wish to stow the key fob within the car, ensure that it is not left in plain view.

i *NOTE: If the message 'key not found in vehicle' appears on the instrument cluster, reposition key fob until it is detected.*

i *NOTE: Do not stow the key fob in the centre console stowage compartment, in the cup holders, in the stowage nets between the seats, or on the shelf immediately behind the seats as the system will not detect its presence and the engine will not start.*

Discharged battery

If you are unfortunate enough to experience a fully discharged battery, the vehicle can still be opened using the mechanical key, see Unlocking - discharged battery, page 5.24.

Car washes

i *NOTE: To prevent inadvertent opening of a door when using an automatic car wash, always lock the doors before entering the wash. If you intend to remain inside the vehicle, press the interior central locking button to ensure the doors do not open. The light in the button will illuminate to indicate that the doors are locked.*

For more information, see Washing your McLaren, page 5.38.

If using a car wash where your car will remain stationary during the wash cycle and you intend to exit the vehicle prior to washing, lock it using the key fob and stand well clear of the vehicle and the car wash, to ensure that the key fob is at least 3 metres (10 feet) away or more from the vehicle and car wash.

BEFORE YOU DRIVE

OPENING AND CLOSING

Opening a door



1. Press the button **(1)** firmly to unlock and unlatch the door.

WARNING: Always stand to the rear of the door before opening it, as the opening action may cause injury. The speed that the door opens will be affected by ambient temperature.

NOTE: Because the door opens outwards and then upwards, ensure sufficient side and overhead clearance before opening a door, see *Vehicle dimensions*, page 6.6.

2. If keyless entry is used, the front, rear and side directional indicators (market specific) will flash twice, and the anti-theft alarm system is deactivated.
3. The door latch will then release, allowing the door to be partially raised before it automatically swings outwards and upwards. The mirrors will unfold if folded.

NOTE: If the vehicle is dirty or wet, it is advisable to open the doors using the key fob.

A quick double press of the unlock button will unlatch the driver's door. A long press and hold on the unlock button will unlatch the passenger's door.

NOTE: When the door is opened, the window will lower slightly. It will raise to the closed position once the door is shut. If the window does not lower, take care when opening and closing the door. Do not force the door during opening or closing, as this could lead to the door seals or window becoming damaged.

NOTE: A sustained long press and hold on the unlock button will automatically lower the windows. The windows will continue to lower until the unlock button is released or the windows are fully lowered.

NOTE: If the vehicle is unlocked using the key fob but the doors or luggage compartment are not opened, the vehicle will relock after 30 seconds.

BEFORE YOU DRIVE

OPENING AND CLOSING

Locking a door



1. Close the door. See Closing a door, page 1.10.
2. To lock the vehicle using the key fob, press the lock button. The front, rear and side direction indicators flash in a rapid, circular sequence around the car. The anti-theft alarm system is activated.

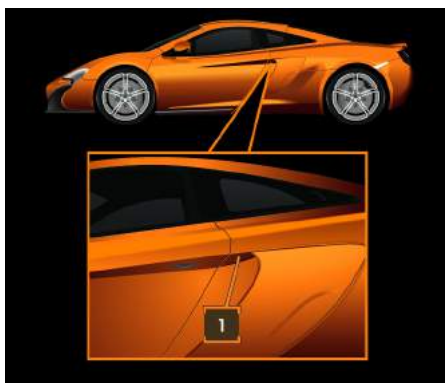

3. If using the keyless entry feature, touch the lock sensor (1) on the bodyside.

- i** NOTE: Ensure the key is within a 1.5 metres (5 feet) range of the door sensors when using the keyless entry feature.
- i** NOTE: The lock sensor will recognise a single touch.

i NOTE: A sustained long touch and hold on the lock sensor will automatically raise the window. The window will continue to raise until the lock sensor is released or the window is fully closed.

4. The direction indicators flash to indicate that the anti-theft alarm system is activated and the mirrors will fold.

i NOTE: When the door is opened the door glass will lower slightly to avoid contact with other parts of the vehicle. When the door is closed the glass will rise to the closed position automatically. If for any reason the door glass does not rise it is likely that the system has sensed a “trap” event. This can be caused by debris in the glass channel or misalignment of the glass. Ensure there are no obvious signs of debris in the glass channel, and hold the lock button. The glass will rise providing the door is correctly closed and there are no obstructions preventing it rising. If the glass does not close, or the glass repeatedly fails to automatically raise, contact your McLaren Retailer.

BEFORE YOU DRIVE

OPENING AND CLOSING

Mislock



If either the doors, the luggage compartment lid or the engine cover are left open, or the key fob is still inside the vehicle, an audible 'mislock' signal will sound when an attempt to lock the vehicle is made when the lock button on the key fob is pressed. On Spider models, the 'mislock' signal will also sound when an attempt is made to lock the vehicle if the tonneau cover is not fully closed or if the roof is not fully opened or fully closed.

i *NOTE: If the doors are open or the key fob is still inside the vehicle, a momentary sounding of the alarm horn will alert you. If the luggage compartment lid or engine cover is open, a long tone will alert you. The long tone will also indicate that the tonneau cover is open or the roof is not fully open or fully closed on Spider models.*

Check that the doors, the luggage compartment lid, the engine cover and the tonneau cover (Spider only) are all closed and that the roof is fully open or fully closed (Spider only), then relock the vehicle.

i *NOTE: The car can be locked/alarmed with the luggage compartment open. A long tone is sounded to alert you of this condition, and differs to the short tone sounded for door open/key in car mislock. The luggage compartment will become alarmed as soon as the luggage compartment lid is closed. This will allow you to connect the battery charger to the charging point in the luggage compartment whilst leaving the rest of the vehicle locked.*

BEFORE YOU DRIVE

OPENING AND CLOSING

Individual settings

If you frequently travel without passengers, you can change the locking system so that only the driver's door is unlocked, see Auto Door Lock, page 3.14.

If only the driver's door has been configured to unlock, the passenger's door can only be unlocked by either pulling the passenger's door internal handle, pressing the unlock button on the key fob again or by unlocking the car from the central locking button on the centre console.

Locking and unlocking from inside



1. Press the central locking button to lock the vehicle, the light in the button will illuminate to indicate that the vehicle is locked.
2. Press the central locking button again to unlock the vehicle and the light in the button will extinguish.

BEFORE YOU DRIVE

OPENING AND CLOSING

Opening a door from inside

A door can be opened from inside the vehicle at any time, even if it has been locked. Open the doors only if the vehicle is stationary and road and traffic conditions permit.

i *NOTE: Because the door opens outwards and then upwards, ensure sufficient side and overhead clearance before opening a door.*



1. Pull door handle upwards, in direction of arrow, and push the door outwards until the opening mechanism takes over. The door will then swing outwards and upwards automatically.

i *NOTE: When the door is opened, the window will lower slightly. It will raise to the closed position once the door is shut. If the window does not lower, take care when opening and closing the door. Do not force the door during opening or closing, as this could lead to the door seals or window becoming damaged.*

BEFORE YOU DRIVE

OPENING AND CLOSING

Closing a door

1. Push/pull the door downwards and ensure that it latches securely.

WARNING: Keep hands and other objects clear of the door edge when closing. This is particularly important for vehicles fitted with soft close latches as the door will automatically continue to the fully closed position when the first catch has engaged. There is no anti-trap feature preventing the door closing if an item or body part is trapped between the door and the door aperture, serious injury and vehicle damage may occur.

If the window does not close, this may be due to an anti-trap event. Try one of the following:

- reopen and close door
- press lock button on key fob to request window close
- lock vehicle using button on underside of door panel



In the event of continuous anti-trap events, press the button **(1)** for a few seconds. The window will continue to rise until you remove your hand from the button. Only attempt this if the above methods do not resolve the problem.

NOTE: Do not force the door closed, the door seals or window could be damaged.

Automatic locking

The doors and the luggage compartment lock automatically after the vehicle has driven away.

NOTE: The doors unlock automatically in an accident if the force of the impact exceeds a predetermined level.

The automatic locking function is selectable in the vehicle settings section of the instrument cluster, see Auto Door Lock, page 3.14. If automatic locking is ON, the interior central locking button will illuminate once the vehicle locks on drive away.

BEFORE YOU DRIVE

OPENING AND CLOSING

Engine cover

Opening

 **WARNING:** The exhaust tail pipes can be very hot and there is a risk of severe burns. Only open the engine cover from the side of the vehicle.

 **WARNING:** There is a risk of injury if the engine cover is open, even when the engine is not running.

Engine components become very hot and there is a risk of severe burns.

The engine ignition system carries a high voltage. Never touch ignition system components; ignition coils, ignition wiring (spark plug connections).



1. Press the release button on the rear edge of the driver's door, the engine cover will open slightly.



2. From the side of the vehicle, grasp the lower edge and lift the engine cover. The gas struts will support it in the raised position.

BEFORE YOU DRIVE

OPENING AND CLOSING

Closing

WARNING: The exhaust tail pipes can be very hot and there is a risk of severe burns. Only close the engine cover from the side of the vehicle.

Pull the engine cover down squarely from the side of the vehicle and ensure that the cover latches securely on both sides.

Luggage compartment

Opening



1. Press the button on the key fob the luggage compartment will unlock and open slightly.

i *NOTE: The luggage compartment is located at the front of the vehicle.*



2. Alternatively, press the button to unlock and open the luggage compartment.

i *NOTE: The luggage compartment will only open if the vehicle is stationary.*



3. Release the safety latch and open the luggage compartment.

Closing



WARNING: Ensure that no one can be trapped as you close the luggage compartment.

1. Pull the luggage compartment lid down firmly and ensure that it is latched securely.



NOTE: Do not leave the key fob in the luggage compartment, as the vehicle may lock, and you may be locked out of the car.



NOTE: If the vehicle had previously been locked, it will still be locked and the direction indicators will flash as the lid closes.

2. The luggage compartment will become alarmed as soon as the luggage compartment lid is closed.



NOTE: The car can be locked/alarmed with the luggage compartment open. This will allow you to charge the battery while leaving the rest of the vehicle locked. A long tone is sounded to alert you of this.

BEFORE YOU DRIVE

OPENING AND CLOSING

Retractable Roof - Spider models

The retractable roof comprises of two lightweight panels which, when operated, fold swiftly beneath the tonneau panel located behind the cockpit.

The roof is operated using the switch on the centre console.

The roof can be operated at speeds up to 19 mph (30 kph).

WARNING: Do not place any objects between the moving parts of the roof. Make sure any occupants or bystanders are clear of the roof during operation. Operation of the roof may cause personal injury or damage to components.

WARNING: Do not operate the roof if the stowage bags are fitted and in use in the tonneau area. The roof system and/or the backlight glass could be damaged.

WARNING: To avoid damaging the operating mechanism and the vehicle interior, carefully remove surface water, ice or snow before operating the roof.

The roof must only be operated if the stowage bags are not in use and stored securely in the stowage mounts.

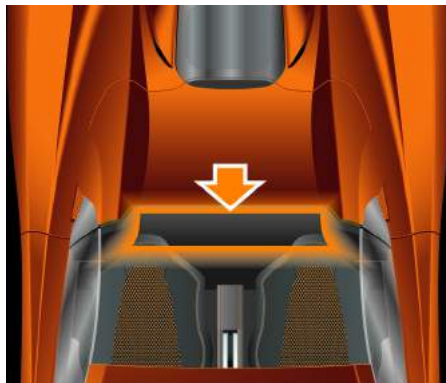

NOTE: Do not sit, stand or place any load on the backlight interior trim panel.

If you experience any problems with the roof, contact your Authorised McLaren Retailer immediately.

NOTE: If the vehicle is stopped with the roof open, it is possible to close the roof before the vehicle goes to sleep to leave it secure.

Roof Operating Temperature

Minimum ambient operating temperature	-10°C (14°F)
---------------------------------------	--------------

NOTE: Roof operation is inhibited when operated below the minimum ambient operating temperature.

BEFORE YOU DRIVE

OPENING AND CLOSING

Opening the roof

1. The vehicle must be awake with key present.

i NOTE: Operation of the roof will be halted whilst the engine is cranking.



2. Press and hold the switch to operate the roof. If you release the switch, the roof will stop until you press the switch again.

i NOTE: If the tonneau cover has been opened at any time while the roof is closed, the message 'Confirm Tonneau Empty' will be displayed on the left-hand instrument cluster.

3. Check the tonneau area is empty and the stowage bags are correctly stowed. Press OK on the menu stalk, once you have confirmed this.



4. Press and hold the switch until the roof is fully open (stowed).

i NOTE: When the roof starts to move, the tonneau cover will open and the backlight glass will drop slightly. The message 'Roof Operation In Progress' will appear on the left-hand instrument cluster.

5. Once the roof is fully open (stowed), the tonneau cover will close and the backlight glass will return to an aero position to reduce wind buffeting in the cockpit. The message 'Roof Open' will appear on the left-hand instrument cluster. An audible tone will confirm that the roof cycle is complete.
6. If the switch is held in the down position after the operation has completed, the windows and backlight will open fully.
7. If the vehicle speed rises above 19 mph (30 kph) while the roof is being operated, roof operation is paused. The message 'Reduce Vehicle Speed, Release and Re-press Button For Roof Operation' will appear on the left-hand instrument cluster.

BEFORE YOU DRIVE

OPENING AND CLOSING

8. Reduce the vehicle speed to below 19 mph (30 kph) and release the switch. The message 'Continue Roof Cycle' will appear on the left-hand instrument cluster. Press the switch again to continue desired roof cycle.

i *NOTE: If the roof is not fully opened or closed, within 7 minutes the system will lower the roof to the nearest rest position. If this happens the roof will not be securely latched and the roof must be fully opened/closed to make it secure before driving the vehicle.*

Closing the roof

1. The vehicle must be awake with key present.

i *NOTE: Operation of the roof will be halted while the engine is cranking.*



2. Pull and hold the switch until the roof is in the fully raised (closed) position.
3. If you release the switch, the roof will stop until you press the switch again.
4. If the vehicle speed rises above 19 mph (30 kph) while the roof is being operated, roof operation is paused. The message 'Reduce Vehicle Speed, Release and Re-press Button For Roof Operation' will appear on the left-hand instrument cluster.

5. Reduce the vehicle speed to below 19 mph (30 kph) and release the switch. The message 'Continue Roof Cycle' will appear on the left-hand instrument cluster.
6. Pull the switch to continue closing until the roof and tonneau are fully closed and latched. The window and backlight glass will raise to the fully closed position. An audible tone will confirm that the roof cycle is complete.
7. Continuing to hold the switch after the roof cycle is complete will lower the window and backlight glass.

i *NOTE: If the roof is not fully opened or closed, within 7 minutes the system will lower the roof to the nearest rest position. If this happens the roof will not be securely latched and the roof must be fully opened/closed to make it secure before driving the vehicle.*

BEFORE YOU DRIVE

OPENING AND CLOSING

Backlight - Spider models

WARNING: If the tonneau area is being used to stow luggage, please ensure that the stowage bags provided with the vehicle are used. If not, operation of the backlight could lead to damage to the backlight glass.

Lower the backlight, with the roof open, to obtain additional air flow around the cockpit. Raise the backlight to an aero position to reduce wind buffeting in the cockpit.

i NOTE: It is only possible to operate the backlight if the vehicle is awake with the key present.

The backlight switch is located on the centre console.

i NOTE: If you experience any problems with the backlight, contact your Authorised McLaren Retailer immediately.

Opening

1. The vehicle must be awake with the key present.



2. Press and hold the switch to lower the backlight. If you release the switch, the backlight will stop until you press the switch again.

i NOTE: If the tonneau cover has been opened while the roof is closed, the message 'Confirm Tonneau Empty' will be displayed on the left-hand instrument cluster.

3. Check the tonneau area is empty and the stowage bags are correctly stowed. Press OK on the menu stalk, once you have confirmed this.

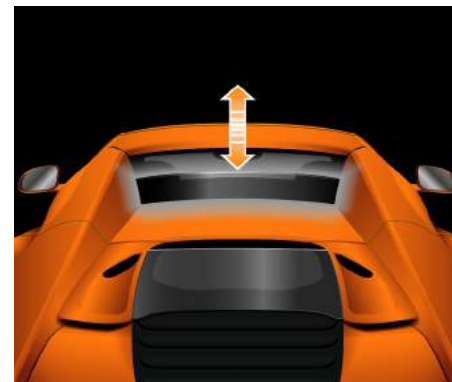

4. Press and hold the backlight switch to lower the backlight to the desired position.

i NOTE: Do not fully open the backlight when it is raining or snowing, as water could enter the cabin area and affect electrical components.

BEFORE YOU DRIVE

OPENING AND CLOSING

Closing

1. The vehicle must be awake with the key present.



2. Pull and hold the backlight switch to raise the backlight until the backlight is in the desired position.

i *NOTE: If the vehicle is stopped with the backlight open, you are able to close the backlight before the vehicle goes to sleep to leave it secure.*

BEFORE YOU DRIVE

OPENING AND CLOSING

Tonneau Cover - Spider models

The tonneau cover is the panel behind the cockpit. The tonneau cover can be opened and closed and allows access to the area below.

The retractable roof is stowed in the area underneath the tonneau cover when the roof has been lowered. The tonneau cover is then closed.

Opening

1. The vehicle must be awake with key present.

 **WARNING: Do not place any objects between the moving parts of the tonneau. Make sure any occupants or bystanders are clear of the tonneau during operation. Operation of the tonneau may cause personal injury or damage to components.**

 **NOTE: Do not operate the tonneau cover whilst loading/unloading of the tonneau area is taking place. The vehicle will remain awake for a maximum of fifteen minutes while the tonneau is open.**

 **NOTE: Access to the tonneau storage area can only be made using the tonneau open/close buttons on the driver's door switch panel.**

 **NOTE: The key must be within range of the driver's door to enable tonneau control.**



2. Press and hold the button on the rear edge of the driver's door until the tonneau cover is fully open.

 **NOTE: The tonneau cover cannot be opened if the roof is open.**

3. Check the tonneau area is empty and the stowage bags are correctly stowed. Press OK on the menu stalk, once you have confirmed this.



4. If the vehicle is driven whilst the tonneau cover is open, the message 'Tonneau Cover Open' will appear on the left-hand display, accompanied by an audible alert.

BEFORE YOU DRIVE

OPENING AND CLOSING

- i** *NOTE: Only stow items in the tonneau area in the storage bags provided with your McLaren. See Stowage Luggage - Spider models, page 1.21.*

Closing

- !** **WARNING: Ensure that no one can be trapped as you close the tonneau cover.**



1. Press and hold the button on the rear edge of the driver's door until the tonneau cover is fully closed.

- i** *NOTE: The tonneau cover can be closed for up to 15 minutes once it has been opened whilst the ignition is off. If this time has elapsed, switch the ignition on again to close the tonneau cover.*

- i** *NOTE: The message 'Tonneau Operation In Progress' will appear on the left-hand display.*

- i** *NOTE: The tonneau area will be alarmed when the vehicle is locked.*

- i** *NOTE: Do not overfill the stowage bags. This could cause a tonneau cover fault, contact your Authorised McLaren Retailer immediately.*

BEFORE YOU DRIVE

STOWING LUGGAGE

Stowage Luggage - Spider models

When the roof is raised, the area underneath the tonneau cover can be used for storing small items. Your McLaren is supplied with two stowage bags for this purpose.

WARNING: Do not place loose items in the tonneau area. This could lead to damage to the roof system and/or the backlight glass.

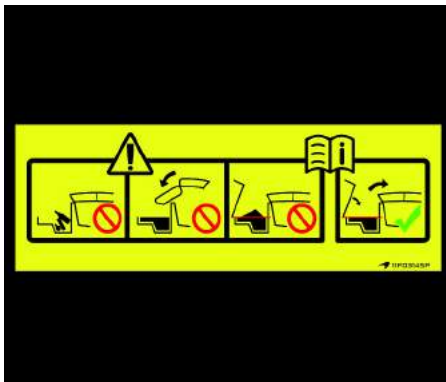

The stowage bags can be filled while in the tonneau area or out of the vehicle.

- i** *NOTE: Only use the stowage bags provided. No other type of luggage bag can be used. The warning label on the interior of the tonneau cover confirms this.*
- i** *NOTE: Ensure the contents do not exceed the recommended fill level identified by the red line on the rear of the bulkhead area. The warning label on the bulkhead confirms this.*
- i** *NOTE: Do not overfill the stowage bags. The weight of each stowage bag and contents should not exceed 15 kg (33 lbs).*
- i** *NOTE: Do not fill the stowage bags with any of the following:*

 - *hazardous and/or volatile compounds or liquids*
 - *heavy and/or sharp objects*
 - *foods and/or liquids affected by heat*
 - *fragile items or items which are easily breakable*

BEFORE YOU DRIVE

STOWING LUGGAGE

Installing stowage bags

1. Open the tonneau cover. Tonneau Cover - Spider models, page 1.19

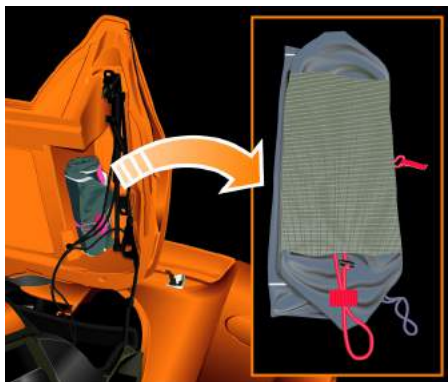

2. Remove the stowage bags from the mounts inside the tonneau cover.
3. Release the toggle and unroll the stowage bags.
4. Place the items inside the stowage bags and/or place the stowage bags in the tonneau area.

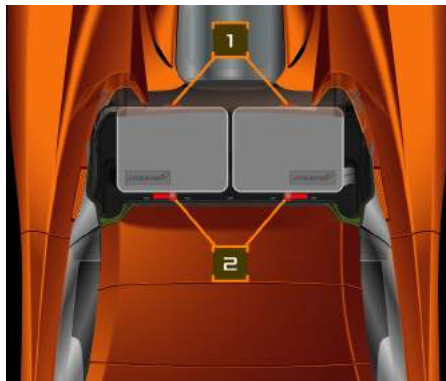

5. Ensure the McLaren logos are facing towards the rear bulkhead and outboard of the vehicle.
6. Attach the carry handle (1) to the fixing area.
7. Attach the secondary loop (2) to the secondary fixing point.

i NOTE: Zip the stowage bags fully closed when in use. This will prevent items from falling out and damaging the roof system and/or backlight glass.

i NOTE: Ensure the stowage bags are securely fitted when in use and are attached to all the location points.

BEFORE YOU DRIVE

STOWING LUGGAGE

Removing and storing the stowage bags

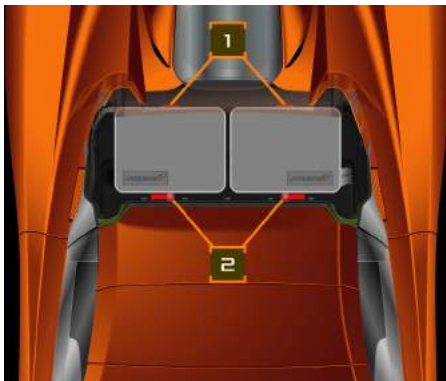

1. Detach the carry handle (1) from the fixing area.
2. Detach the securing loop (2) from the secondary fixing point.
3. Remove the stowage bag from the tonneau area and remove the contents.
4. Place the empty stowage bag on a flat surface with the McLaren logo facing downwards.

5. Fold in the thinner portion of the stowage bag, followed by the thicker portion and then turn the stowage bag over.
6. With the McLaren logo facing upwards, tightly roll the stowage bag and secure by wrapping the toggle around it and under the locating point.
7. Place the stowage bag in the tonneau area into the stowage mounts, ensuring it is secure by placing the securing strap over the stowage mount.

i NOTE: This process is detailed on a label attached to the inner surface of the tonneau cover.

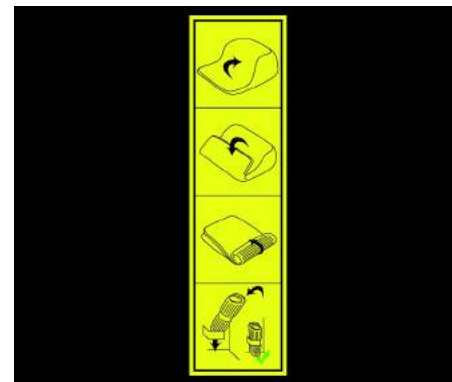

8. Repeat the process for the second stowage bag.

i NOTE: Make sure the stowage bags are fitted to the stowage mounts when not in use.

BEFORE YOU DRIVE

ANTI-THEFT SYSTEM

Alarm system

A visual and audible alarm is triggered if the alarm system is armed and any of the following are opened:

- a door
- the engine cover
- the luggage compartment lid
- the tonneau cover (Spider only)

i *NOTE: The alarm remains triggered even if you close the open aperture. To silence the alarm, unlock the vehicle.*

The alarm system also incorporates the following features:

- tow-away protection
- interior motion sensor*
- centre console bin*

Arming the alarm system

1. Lock the vehicle (using the keyless system or the key fob). The anti-theft alarm system will be armed after approximately 5 seconds.



2. The light in the central locking button will illuminate for approximately 60 seconds after locking the vehicle

Disarming the alarm system

1. Unlock the vehicle (using the keyless system or the key fob), the alarm will disarm and the light in central locking button will stop flashing.

Immobiliser

The immobiliser prevents your McLaren from being started by an unauthorised person.

The vehicle is automatically immobilised when it senses that there is no key fob present in the vehicle.

Remobilisation occurs when a key fob is sensed inside the vehicle.

i *NOTE: Immobilisation will only occur if the engine is not running*

BEFORE YOU DRIVE

ANTI-THEFT SYSTEM

Tow-away protection

Tow-away protection is designed to prevent any attempt to steal the vehicle by suspended tow or by lifting onto a trailer.

The alarm is triggered if the vehicle is raised or tilted in any way.

Tow-away protection is armed approximately 30 seconds after the vehicle has been locked and is disarmed when the vehicle is unlocked.

Disabling tow-away protection

Disable tow-away protection manually if your vehicle is being transported, e.g. loaded onto a ferry or vehicle transporter or your vehicle is parked on a movable surface, e.g. in a split-level garage.



1. To disable tow-away protection, switch off the ignition, open the driver's door and press the button on the rear edge of the driver's door. The light in the switch will illuminate to indicate that tow-away protection has been disabled.

i *NOTE: You cannot disable tow-away protection if the ignition is switched on.*

2. Close the driver's door and lock the vehicle (using the keyless system or the key fob). Tow-away protection remains disabled until you unlock the vehicle.

BEFORE YOU DRIVE

ANTI-THEFT SYSTEM

Interior motion sensor*

The alarm is triggered if your vehicle is locked and movement is detected inside, e.g. if someone breaks a window or reaches into the vehicle through an open window.

The interior motion sensor is armed approximately 30 seconds after the vehicle has been locked and is disarmed when the vehicle is unlocked.

i *NOTE: To prevent false alarms close the windows when leaving the vehicle and do not hang anything on the interior mirror.*

Disabling the interior motion sensor

Disable the interior motion sensor if people or animals are to remain in the locked vehicle.



1. To disable the interior motion sensor, switch off the ignition, open the driver's door and press the button on the rear edge of the driver's door. The light in the switch will illuminate to indicate that the interior motion sensor has been disabled.

i *NOTE: You cannot disable the interior motion sensor if the ignition is switched on.*

2. Close the driver's door and lock the vehicle (using the keyless system or the key fob). The interior motion sensor remains disabled until you unlock the vehicle.

Safety

WARNING: Adjust the driver's seat when the vehicle is stationary. You may not be able to observe road and traffic conditions and you could lose control of the vehicle as a result of the seat moving. You could therefore cause an accident.

WARNING: The seats can be moved even without a key fob in the vehicle. Do not leave children unattended in the vehicle, they could be injured if a seat is moved accidentally.

WARNING: Ensure that no one can become trapped as the seat moves.

To reduce the risk of injuries in the event of an accident, observe the following:

- All vehicle occupants must select a seat position that allows the seat belt to be worn correctly, but is as far away from the front air bags as possible. The position of the driver's seat must allow the driver to drive the vehicle safely. The distance from the driver's seat to the pedals must be

such that the driver can fully depress the pedals. The distance between the driver's chest and the centre of the air bag cover must be more than 25 centimetres (10 inches). The driver's arms should be slightly bent when holding the steering wheel.

- Vehicle occupants must always wear their seat belt correctly.
- Position the passenger's seat as far back as is comfortable.

WARNING: McLaren Automotive does not recommend the use of child seats in this vehicle, but if you choose to do so, please follow the below guidelines:

- Children under 1.35 metres (4 ft 5 in) tall or younger than 12 years of age must be secured in a suitable child restraint.
- If you are using a child restraint on the passenger's seat, move the seat as far back as possible.

Manual seats

Manual seat forward and rearward adjustment



Lift the lever, move the seat to the desired position and release the lever to lock the seat.

WARNING: Ensure the seat is locked in position before driving.

i *NOTE: Ensure that there are no items of luggage in the footwell or behind, underneath or to the side of the seats. This may lead to the seats being damaged.*

BEFORE YOU DRIVE

SEATS

Manual seat backrest rake adjustment

⚠ WARNING: To minimise the risk of injury, position the backrest as close as possible to vertical.

i NOTE: Do not recline the seat backrest so that it repeatedly contacts the rear bulkhead as this could lead to damage over a period of time.



Lift the lever, move the seat backrest to the position required, and release the lever.

Manual seat height adjustment



Press the switch up or down until the seat reaches the desired height.

i NOTE: Height adjustment is only available on the driver's seat.

Racing seats*

Seat Forward and Rearward Adjustment



i NOTE: It is only possible to adjust the forward and rearward position of the seat.

To adjust the seat, lift the lever and slide the seat to the desired position, ensuring you can comfortably reach all pedals and are able to move them through their full travel.

⚠ WARNING: Ensure the seat is locked in position before driving.

BEFORE YOU DRIVE

SEATS

i *NOTE: Ensure that there are no items of luggage in the footwell or adjacent to the seats as this may lead to the seats being damaged or not getting full adjustment.*

Seat Height and Tilt Adjustment

For seat height and tilt adjustment, contact your McLaren Retailer.

! **WARNING: Seat height adjustment should only be carried out by your McLaren Retailer.**

Electric seats*

Electric seat adjustment

The seat adjustment switch is on the front face of the seat base and can be used when the vehicle is in any awake status, see Vehicle electrical status, page 2.2

i *NOTE: Ensure there are no items of luggage in the footwell or behind, beneath or to the side of the seats, or the seats may be damaged.*

Forward and rearward adjustment

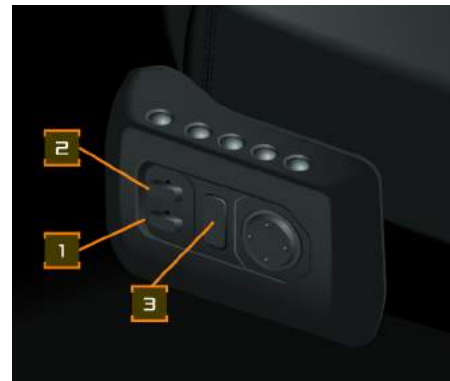

Press the switch **(1)** up or down until the seat reaches the desired position.

BEFORE YOU DRIVE

SEATS

Electric seat backrest rake adjustment

⚠ WARNING: To minimise the risk of injury, position the backrest as close as possible to vertical.

i *NOTE:* When reclining the backrest, the seat base will automatically move forward, depending on its position relative to the rear bulkhead. If the seat base is moved backwards when the backrest is fully reclined, the backrest will automatically raise to prevent contact with the rear bulkhead.

i *NOTE:* Do not recline the seat backrest so that it repeatedly contacts the rear bulkhead as this could lead to damage over a period of time.

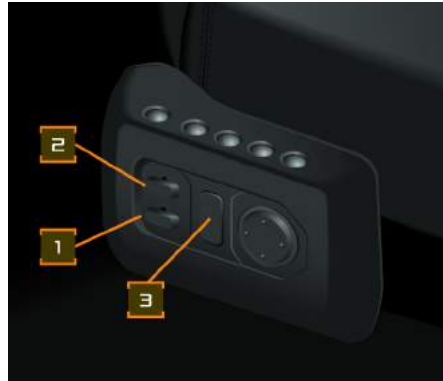

Press the switch **(2)** up or down until the backrest is in the required position.

⚠ WARNING: Ensure there are no items beneath the passenger's seat or the occupant protection system may not function correctly.

Electric seat height adjustment

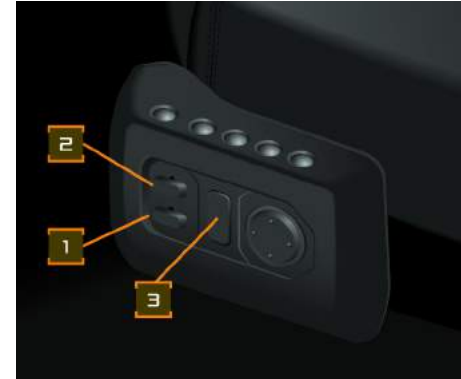

Press the switch **(3)** up or down until the seat reaches the desired height.

Electric seat lumbar adjustment

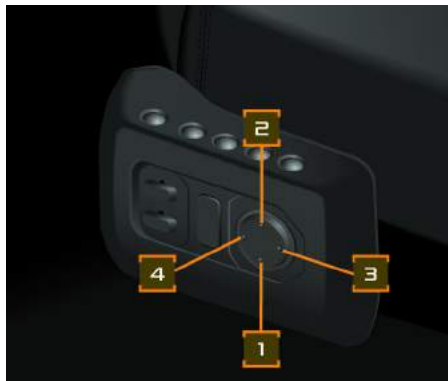

Press **(1)** to lower or **(2)** to raise the position of the lumbar support.

Press **(3)** to inflate or **(4)** to deflate the selected lumbar support.

Storing a seat and mirror position

Specific seat and exterior mirror positions can be stored for up to three drivers.

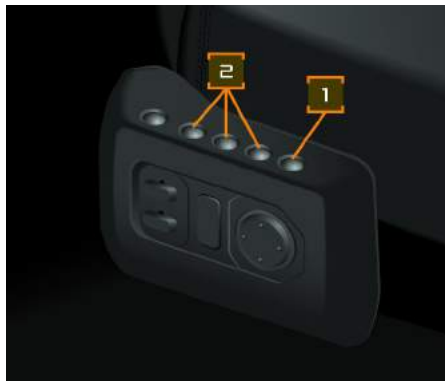

Set the seat, mirrors, and steering wheel to the desired positions; see Electric seats*, page 1.29, Electric steering wheel adjustment*, page 1.35 and Exterior mirrors, page 1.46.

Press and hold the memory set button **(1)** and then simultaneously press any of the memory position buttons **(2)** to store the setting.

Recalling a seat and mirror position

 **WARNING:** Only recall a seat, mirror position and steering wheel position, when the vehicle is stationary. You may not be able to observe road and traffic conditions and you could lose control of the vehicle as a result of the seat moving. You could therefore cause an accident.

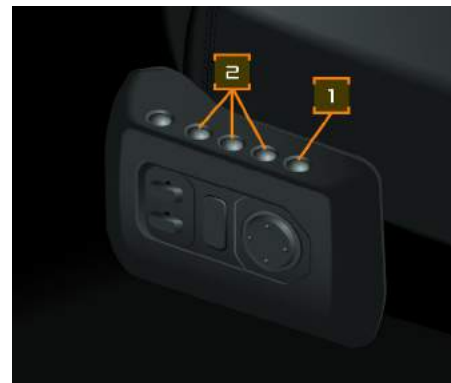

Press the button **(2)** where the required setting is stored, and hold until the seat and mirrors have completed their adjustment.

Comfort entry/exit*

 **WARNING: Ensure that no one can become trapped as the seat moves.**

When comfort entry/exit is active, the driver's seat will move fully rearwards and to its lowest position when the engine is off and the driver's door is opened.

This assists exit from the vehicle. To switch the feature on or off, see Comfort Entry/Exit*, page 3.14.

Use the seat, mirror and if fitted, electric steering wheel, memory recall feature to return the seat to your preferred position. If no seat positions are stored in memory, readjust the seat using the controls.

Seat memory - Stalk return

After using comfort entry/exit, you can return the driver's seat to its most recent position using the control stalk on the left of the steering column.

The function will only be available when "To Return Seat, Pull left Stalk or Press OK to Clear" is displayed on the left-hand display.

The vehicle must be awake with ignition off, the driver's door closed, and comfort entry/exit ON.

1. Pull the control stalk towards you once to initiate the comfort entry function.
2. If at any point you wish to cancel the function, operate the control stalk or open the driver's door. A message "Seat Returning, Operate Stalk or Open Door to Cancel" will appear in the left-hand display.

 **NOTE:** *This function will only return the seat to the position it was in prior to the comfort entry/exit function being used. It will not use any of the seat memory positions, unless the previous position was one of the stored seat memory positions.*

3. If the seat is manually adjusted before the stalk is used, the function will be lost and will not be available until the next time comfort entry/exit function is used.

-  **NOTE:** *Cancel the comfort entry/entry function by starting the engine, or by pressing the seat switch pack while the seat is returning to position.*
4. If the comfort entry/entry function is cancelled, it will not be possible to return the seat to its previous position using this function. The message in the left-hand display will disappear and the control stalk will return to its normal use. The function will be available when comfort entry/exit is next used.
5. Once the seat has returned to its previous position, the message in the left-hand display will disappear and an audible alert will confirm that the seat return has been completed.

Heated seats



WARNING: To avoid the risk of injury, constantly monitor the seat temperature.



WARNING: The heated seats will not switch off automatically once it reaches its optimum temperature dependent on the level selected. Please ensure the switch of the heated seat function is turned off once the desired heat/period of heat has been achieved.



Press button **(1)** once to switch seat heating to the low temperature setting, the button illuminates amber. Press again to switch to the high temperature setting, the button illuminates red.

Press button **(1)** again to switch seat heating off.

The seat heater will remain in operation until switched off.

BEFORE YOU DRIVE

STEERING WHEEL AND STEERING COLUMN

Manual steering wheel adjustment

⚠ WARNING: Only adjust the steering wheel when the vehicle is stationary. You may not be able to observe road and traffic conditions safely. This could lead to you losing control of the vehicle which may result in an accident.

The steering wheel can be adjusted for height and reach.



Push the lever (highlighted) downwards and position the steering wheel so that:

- your arms are slightly bent when you hold the wheel
- you can move your legs freely
- you can see all the displays in the instrument cluster clearly

Pull the lever to secure the steering wheel. Ensure the lever is locked before driving.

BEFORE YOU DRIVE

STEERING WHEEL AND STEERING COLUMN

Electric steering wheel adjustment*

WARNING: Only adjust the steering wheel when the vehicle is stationary. You may not be able to observe road and traffic conditions safely. This could lead to you losing control of the vehicle which may result in an accident.

The steering wheel position may be adjusted for height and reach using the column control switch when the vehicle is in any awake status, see Vehicle electrical status, page 2.2.

The column control switch is located on the left hand side of the steering column.

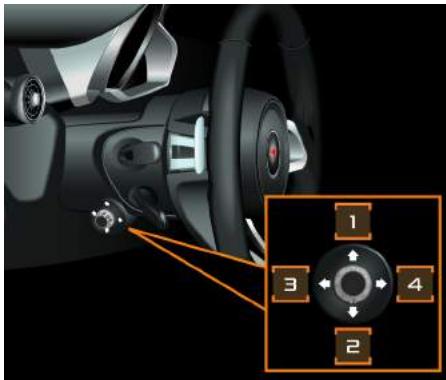

1. Height: Raise
2. Height: Lower
3. Reach: Away
4. Reach: Towards

Moving the column control switch in directions 1 & 2 adjusts the steering wheel height, raising or lowering the wheel's position.

Moving the column control switch in directions 3 & 4 adjusts the steering wheel reach, moving it closer or further away.

i **NOTE:** The column control switch will only adjust the steering wheel in one direction at a time.

Using the column control switch, position the steering wheel so that:

- your arms are slightly bent when you hold the wheel
- you can move your legs freely
- you can see all the displays in the instrument cluster clearly

Automatic steering wheel adjustment

If your vehicle is equipped with electric seats, the electric steering wheel position is stored when the seat and mirror positions are stored. See "Storing a seat and mirror position" on page 31.

WARNING: Ensure that your hands are kept clear of the wheel and column as the steering wheel moves.

i **NOTE:** Any automatic movement can be cancelled with any input from the column control switch.

BEFORE YOU DRIVE

STEERING WHEEL AND STEERING COLUMN

Comfort entry/exit*

When comfort entry/exit is active, the steering wheel and column will move fully forward (away from the driver) and to its highest position when the engine is off and the driver's door is opened.

You can return the steering wheel and column to its most recent position using the control stalk on the left of the steering column. See "Comfort entry/exit*" on page 32.

 **WARNING: Ensure that your hands are kept clear of the wheel and column as the steering wheel moves.**

 *NOTE: Any automatic movement can be cancelled with any input from the column control switch.*

Horn

Press the centre of the steering wheel to operate the horn.

 *NOTE: The horn can be operated when the ignition is switched off.*

Seat belts

Seat belts and child restraint systems are the most effective means of restraining vehicle occupants from impact forces, which, in turn, minimises the danger of injury from interior impacts and the effects of whiplash.

 **WARNING: A seat belt which is not worn, worn incorrectly, or has not been engaged fully in the seat belt buckle, cannot perform its intended function. To avoid injuries, ensure that all vehicle occupants wear their seat belt correctly at all times.**

Ensure that the belt:

- is routed as low as possible across your pelvic area, i.e. across your hip joints and not across your abdomen
- fits closely
- is not twisted
- is routed across the middle of your shoulder
- lies flat across the mid point of the collar bone between the neck and shoulder
- fits closely across your pelvis by pulling the shoulder belt upwards

Do not secure any objects with a seat belt if the seat belt is being used by a vehicle occupant.

Avoid wearing bulky clothing.

Do not route the belt across sharp edged or fragile objects especially if these are on or in your clothing. The seat belt could be damaged and you could be injured.

Only one person should use each seat belt at any one time.

Never allow children to travel on the lap of another occupant.

Children under 1.35 metres (4 ft 5 in) tall or younger than 12 years of age must be secured in a suitable child restraint. Follow the manufacturer's instructions when installing child restraint systems.

 **WARNING: Pregnant women should wear a seat belt to ensure maximum safety of mother and unborn child. Position the lap belt across the hips, beneath the abdomen and position**

the shoulder belt between the breasts and to the side of the abdomen. Ensure the belt is not slack or twisted.

 **WARNING: The seat belt only provides its intended degree of protection if the seat backrest is positioned close to vertical, and the occupant is sitting upright.**

 **WARNING: The seat belt cannot perform its function correctly if the seat belt or buckle becomes excessively dirty or damaged. Ensure the belt latch engages the buckle fully.**

Check the seat belts regularly to ensure that they are not damaged, or routed over sharp edges and are not trapped. The belt could tear in an accident, causing injury to occupants.

Have seat belts checked if the belts have been damaged or subjected to a heavy load. Work on the seat belts should only be carried out by your McLaren Retailer.

Wearing a seat belt

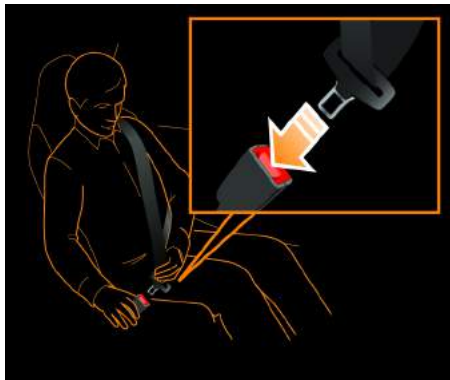

1. Ensure that you are seated comfortably and the controls are within easy reach.
2. Grasp the seat belt latch and pull across the body, ensuring that the belt lies flat across the mid point of the collar bone between the neck and shoulder, then across the chest and pelvis.

3. With the belt correctly positioned insert the latch into the buckle and press until a click is heard to confirm engagement. Check engagement by attempting to pull the latch from the buckle.

Seat belt tensioners

The seat belts incorporate belt tensioners. Belt tensioners apply tension to the seat belts in an accident, pulling them tight against the occupant.

 **WARNING: Do not insert the belt latch into the passenger's seat belt buckle if the passenger's seat is unoccupied. The belt tensioners could be triggered in an accident.**

 **WARNING: Belt tensioners do not correct an incorrect seating position or incorrectly worn seat belts.**

Belt tensioners do not pull occupants back towards the backrests.

The belt tensioner will be triggered for each seat belt, provided the belt latch is engaged in the seat belt buckle, if a head-on or rear-end collision occurs and the vehicle decelerates or accelerates rapidly.

If the belt tensioners are triggered, a bang will be heard, a small amount of dust may be released and the Supplementary Restraint System warning light will illuminate.

 **WARNING: Once triggered (or if you are unsure if they have triggered) you MUST not drive the vehicle. Contact your nearest McLaren Retailer immediately.**

Belt force limiters

The seat belts incorporate belt force limiters. Belt force limiters are tuned to the front air bags and gradually release the tension being applied to the belts during an impact, thus reducing the force exerted on occupants.

Seat belt warning light



The seat belt warning light in the instrument cluster and a warning tone reminds vehicle occupants to fasten their seat belts. The seat belt warning light extinguishes and the warning tone ceases when the driver and passenger have fastened their seat belt.

Supplementary Restraint System

Air bag system

Your McLaren is equipped with the following air bags:

- driver's front air bag in the steering wheel
- passenger's front air bag in the dashboard
- side head air bags in the doors



WARNING: Air bags are not a substitute for correctly worn seat belts, they enhance the level of occupant protection offered by seat belts.



WARNING: Correct operation of the air bags can only occur if the steering wheel, the passenger's air bag cover and the door trim are not covered.



WARNING: To reduce the risk of injuries in the event of an accident, observe the following points:

- Ensure that the driver's chest is at least 25 centimetres (10 inches) from the air bag cover.

- **Do not lean forward over the dashboard while the vehicle is in motion.**
- **Do not rest your feet on the dashboard.**
- **Only hold the steering wheel by the outside of the rim. You could be injured if the air bag deploys and you are holding the inside of the steering wheel.**
- **Occupants, particularly children, must not lean on the doors from inside the vehicle.**
- **Ensure that there are no other objects between the vehicle occupants and the deployment area of the air bags.**
- **Because of the high speed at which air bags deploy, there is a risk of injuries caused by an inflating air bag.**

Air bag replacement



McLaren recommends that airbags are replaced every 15 years to prevent airbags from not firing due to component operating life.

BEFORE YOU DRIVE

OCCUPANT SAFETY

Air bag system modification

If it is necessary to modify the air bag system to accommodate a person with disabilities, please contact your nearest Authorised McLaren Retailer. For more information on Authorised McLaren Retailers, please refer to your service and warranty guide.

Front air bags



The driver's front air bag (1) deploys in front of the steering wheel and the passenger's front air bag (2) deploys in front of and above the dashboard.

The front air bags are deployed if the system determines they can offer additional protection for occupants against head and chest injuries.

i *NOTE: The passenger's front air bag is only triggered if the PASSENGER AIR BAG OFF warning light on the overhead console is NOT illuminated, see Occupant classification system - front passenger's seat, page 1.41.*

Side head air bags

! **WARNING: To reduce the risk of injury to occupants if a side head air bag is triggered, ensure that:**

- **there are no other objects between the vehicle occupants and the deployment area of the air bags**
- **no accessories are attached to the doors**
- **no heavy or sharp objects are left in the pockets in clothing**
- **occupants, particularly children, must not lean on the doors from inside the vehicle**

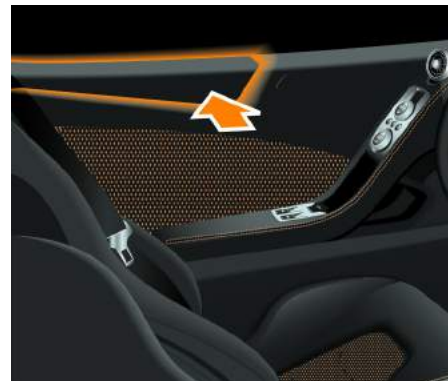

The side head air bags (left-hand highlighted) are located in the upper area of each door panel, and are deployed if the system determines they can offer additional protection for the head of the occupant on the side of the vehicle on which the impact occurs.

i *NOTE: The passenger's side head air bag is only deployed if the passenger's seat is occupied.*

Occupant classification system - front passenger's seat

The system can determine if the passenger's seat is occupied using weight sensors or a capacitance mat fitted in the seat base, and by checking the seat belt buckle engagement on the passenger's seat belt. The passenger's front air bag will not be active unless a specific weight is exceeded. This allows child restraint systems to be used on the passenger's seat.



The status of the air bags is indicated by the PASSENGER AIR BAG OFF warning light on the overhead console.

The PASSENGER AIR BAG OFF warning light illuminates when the ignition is switched on and extinguishes after 5 seconds.

The warning light will remain illuminated if the passenger's seat is unoccupied or if a child seat is fitted.

i *NOTE: The PASSENGER AIR BAG OFF warning light is always illuminated unless the specific weight is exceeded.*

If the PASSENGER AIR BAG OFF warning light is illuminated, the passenger's front air bag is not active. The side head air bag and the belt tensioner on the passenger's side remain active even if the PASSENGER AIR BAG OFF warning light is illuminated.

! **WARNING: If the PASSENGER AIR BAG OFF warning light is not illuminated when the child seat is fitted, the passenger's air bag is not deactivated. The child could be seriously injured if the passenger's air bag inflates.**

! **WARNING: To ensure that the occupant classification system functions correctly, never place objects under the seat. Also never apply additional material such as a blanket, cushion, or aftermarket equipment such as a seat cover, heater, or massager. These items can seriously affect how well the occupant classification system operates. McLaren recommends that**

aftermarket equipment such as covers, heaters, and massagers are NOT used.

 **WARNING:** Any electronic devices that are either active or connected to the 12V accessory socket should not be placed on the passenger's seat. They can affect how the occupant classification system operates.

 **WARNING:** The occupant classification system may become affected if any form of liquid (inclusive of rain) is spilled onto the passenger's seat. If the **PASSENGER AIR BAG OFF** warning light is not illuminated when the seat is unoccupied, do not install a child restraint or allow anyone to occupy the seat. Please contact your nearest McLaren Retailer at your earliest convenience.

 **WARNING:** Do not place sharp objects onto the passenger's seat. These may damage the occupant classification system if they puncture the seat cushion.

 **WARNING:** To ensure that the occupant classification system functions correctly, never place objects (e.g. a cushion) under the child restraint system. The entire base of the child restraint system must be in contact with the seat at all times. If a child restraint system is not fitted correctly it may not provide the intended degree of protection in the event of an accident and may cause injuries.

Air bag deployment

In the event of a collision the air bags are deployed by the Supplementary Restraints System to protect the vehicle occupants. The system can control the number of airbags deployed and partially or fully inflate the

airbags depending on the severity of the collision to provide the best possible protection to the vehicle occupants.

The system uses sensors to rapidly evaluate the collision severity, the number of vehicle occupants, each occupants weight, their physical size and their seated position in relation to their airbags. Once all these factors are known the system will then deploy the necessary airbags and regulate the inflation pressure in the impact zone to ensure the occupants safety.

After an accident the air bags begin to depressurise almost immediately after the inflation process has taken place. The gas used to inflate the airbags escapes through vents in the airbag and this helps reduce the occurrence of major impact injuries to the occupants.

An airbag slows down and restricts the movement of the vehicle occupant reducing the load on the body, but is not a substitute for a correctly worn seat belt.

 **WARNING:** If the air bags are deployed, a bang will be heard and a small amount of fine powder may be released. The noise will not damage your hearing and the powder does not constitute a health hazard nor does it imply that a fire has broken out. This powder could cause short term breathing difficulties for persons suffering from asthma or other respiratory conditions. To prevent breathing difficulties, leave the vehicle as soon as possible or open a window.

 **WARNING:** After an air bag has been triggered, air bag parts are hot, do not touch them. Have the air bags replaced at your McLaren Retailer.

Out Of Position (OOP)

The airbag system in your McLaren has been tested for the correct small child Out Of Position (OOP) operation. OOP can occur if a small child is incorrectly positioned in the passenger's seat in the event of a collision in which the airbags are deployed.

Supplementary Restraint System warning light

 The Supplementary Restraint System performs a self-test at regular intervals when the ignition is switched on and the engine is running.

The warning light in the instrument cluster illuminates when the ignition is switched on and extinguishes 5 seconds after the engine is started.

 **WARNING:** Contact your McLaren retailer immediately should any of the following occur:

- the warning light does not illuminate when you switch on the ignition
- the light does not extinguish 5 seconds after the engine is running
- the light illuminates again, after the engine has started

Safety features

If you are unfortunate enough to be involved in an accident the following events will occur to assist you and any recovery personnel:

- the doors will unlock
- the hazard warning lights will switch on
- the interior lighting will switch on

In some instances, the fuel system will also be switched off.

Child passengers

WARNING: Do not leave children unsupervised in the vehicle even if they are secured in a child restraint. Children could injure themselves on parts of the vehicle, open a door and be seriously or even fatally harmed by prolonged exposure to heat or cold.

If children open a door, they could cause injury to others in doing so or get out of the vehicle and possibly injure themselves or they could be injured by a passing vehicle.

Do not expose the child restraint system to direct sunlight. The metal parts of the child restraint system could burn the child.

Do not carry heavy or hard objects inside the vehicle unless they are secured.

An unsecured or incorrectly positioned load increases the risk of injury to the child during sharp braking, a sudden change of direction or an accident.

Child restraint system

McLaren Automotive does not recommend the use of child seats in this vehicle, but if you choose to do so, please follow the below guidelines:

Secure any child under 1.35 metres (4 feet 5 inches) tall or younger than 12 years of age travelling in the vehicle in an appropriate category restraint according to their weight. Contact your McLaren Retailer for advice.

Category	Weight
Category 0	Up to 10 kg (22 lb)
Category 0+s	Up to 13 kg (28 lb)
Category I	9 to 18 kg (20 to 40 lb)
Category II	15 to 25 kg (34 to 55 lb)
Category III	22 to 36 kg (48 to 80 lb)

Please refer to current national and local laws for specific requirements.



WARNING: Never secure a rearward facing child restraint system on the passenger's seat if the passenger's front air bag is active. The status is indicated by the PASSENGER AIR BAG OFF indicator.



WARNING: If the PASSENGER AIR BAG OFF indicator does not illuminate, do not use a rearward facing child restraint system on the passenger seat. You may use a forward-facing child restraint system on the passenger's seat. The warning label on the passenger's side is there to remind you of this.

WARNING: If a forward facing child seat is fitted to the passenger's seat, make sure that the passenger's seat

is fully rearwards and is positioned at the lowest height. A manual passenger's seat does not have height adjustment.

WARNING: If the child restraint system has not been fitted correctly, the child cannot be restrained in an accident or sudden braking and could be injured. When fitting a child restraint system, observe the manufacturer's instructions on the correct use of the child restraint.

KISI child restraint function

Your McLaren is fitted with a KISI system which is an automatic locking seat belt on the passenger's side designed to temporarily lock the seat belt to securely hold the child restraint in the passenger's seat.

1. Extend the passenger's seat belt fully. The KISI system only engages when the seat belt is fully extended.

NOTE: If the vehicle is parked on a hill the inertia lock may stop the seat belt extending. If this occurs, release the seat

belt slightly and continue to extend the seat belt carefully to avoid the engagement of the inertia lock.

2. Pass the seat belt through the child restraint as described by the child restraint manufacturer and engage the belt latch in the buckle.
3. Adjust the belt so that the lower section is tight against the restraint and allow the upper section to retract. The KISI system will click as the belt retracts.
4. When the seat belt has retracted as far as possible, pull on the upper section to check that the seat belt has locked.

NOTE: The KISI system will disengage when the seat belt has fully retracted and can then be worn as a normal seat belt. Once the KISI system has unlocked, it will be necessary to fully extend the seat belt to engage the KISI system the next time a child restraint is used.

Safety



WARNING: Before driving, adjust all mirrors to give the best possible view of road and traffic conditions.

Interior mirror

Adjust the interior mirror to get a good view of the road and traffic conditions.

Move the lever on the bottom of the mirror to avoid being dazzled by lights from vehicles behind.

Exterior mirrors



WARNING: In some markets, the exterior mirrors have convex glass fitted. This type of mirror enlarges the field of vision, but reduces the size of the image. This means that objects are closer than they appear.

To avoid misjudging the distance to vehicles travelling behind and perhaps causing an accident, check the actual distance of the vehicle, before changing direction.

The exterior mirrors control is located on the dashboard between the steering wheel and the centre console.

BEFORE YOU DRIVE

MIRRORS

Adjusting mirrors

1. Switch the ignition on.



2. Rotate the control to the left **(1)** to adjust the left-hand mirror or to the right **(2)** to adjust the right-hand mirror.
3. Move the control up, down left and right to adjust the mirror to the desired position.

Exterior mirror fold

1. Switch the ignition on.
2. Rotate the control to position **(3)** to fold the mirrors.
3. To unfold the mirrors rotate the control away from position **(3)**.

i *NOTE: If the switch remains in position (3) the mirrors will be folded until the switch is moved.*

Exterior mirror automatic fold

The exterior mirrors can be set so that they fold automatically when the vehicle is locked. Unfolding occurs as a door is opened, not when the vehicle is unlocked. See Auto Fold Mirrors, page 3.14.

Mirror dipping in reverse

The exterior mirrors can be set to dip when reverse is engaged. This provides a view of the ground to the rear of the vehicle. See Reverse Mirror Dip, page 3.15.

Heated mirrors

Exterior mirrors are heated when the rear screen heater is in operation, and the engine is running. They are also heated when the ambient temperature is below 5°C (41°F).

BEFORE YOU DRIVE

LIGHTING

Exterior lighting



1. Headlamp main beam
2. Headlamp dipped beam
3. Direction indicator/Daytime running lamp/ Sidelamp
4. Side direction indicator

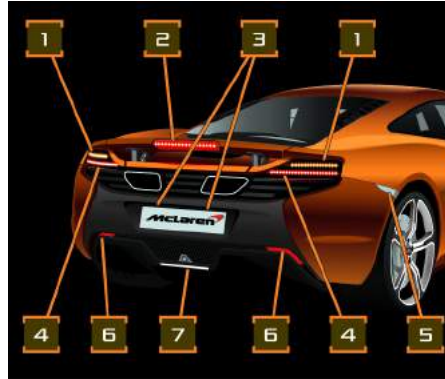

1. Direction indicator
2. Central high mounted stop lamp
3. Licence plate lamp
4. Tail lamp and stop lamp
5. Side marker lamp/bezel
6. Reflector
7. Reverse lamp and rear fog lamp

BEFORE YOU DRIVE

LIGHTING

Light switch

WARNING: The lights do not switch on automatically in foggy conditions.

Automatic light control is only an aid, you are responsible for the vehicle's lighting at all times.

The light switch is located between the steering wheel and the driver's door and has the following positions.

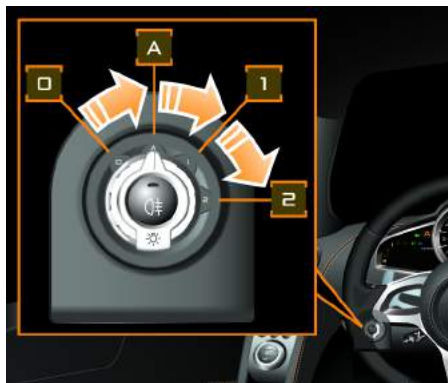

At position **(0)**, the lights are off with the exception of daytime running lamps.

Rotate the control to position **(A)** for automatic light control.

Rotate the control to position **(1)** for sidelamps or position **(2)** for headlamps. The side lamp or headlamp warning light illuminates in the instrument cluster.

i *NOTE: A warning tone sounds if the driver's door is opened while the sidelamps or headlamps are switched on.*

Automatic light control

The sidelamps and dipped beam headlamps are switched on automatically when ambient light falls below a predetermined level.

To switch on automatic light control, turn the light switch to position **(A)**.

i *NOTE: If the vehicle detects rain whilst the light switch is set to position (A) the dipped beam headlamps will switch on automatically, regardless of current external light levels.*

i *NOTE: With the light switch in position (A) and the fog lights switched on, the dipped beam headlamps will also switch*

on irrespective of ambient light conditions. When the rear fog lamps are switched off, the dipped beam headlamps will also switch off dependant on ambient light conditions.

BEFORE YOU DRIVE

LIGHTING

Sidelamps

The sidelamps and the daytime running lamps are a combined series of Light Emitting Diodes (LEDs) located around the outside of the headlamp. The sidelamps operate at a lower intensity than the daytime running lamps, see Daytime running lamps, page 1.51.

The sidelamps, tail lamps and licence plate lamps illuminate when the light switch is turned to position **(1)**.



The sidelamps warning light in the instrument cluster illuminates.

Dipped beam headlights

To switch on the headlights, turn the light switch to **(2)**.



The headlights warning light in the instrument cluster illuminates.



NOTE: On your McLaren, the same headlight dipped beam setting applies for driving on either the left hand or right hand side of the road.

Main beam headlights



To switch to main beams, push the stalk away from you.



The main beam headlights warning light illuminates in the instrument cluster.

Pull the stalk towards you, to revert to dipped beams.

Headlamp flash

Pull the stalk fully towards you.

The main beam headlights operate for as long as the stalk is held.



The main beam headlights warning light illuminates in the instrument cluster.

BEFORE YOU DRIVE

LIGHTING

Daytime running lamps

Your McLaren is fitted with daytime running lamps which illuminate automatically when the ignition is switched on even if all lights are switched off. The sidelamps and the daytime running lamps are a combined series of Light Emitting Diodes located around the outside of the dipped beam headlamp. The daytime running lamps operate at a higher intensity than the sidelamps.

Rear fog lamp

i *NOTE: The rear fog lamp only operates when dipped beam headlamps are on.*

Ensure that the dipped beam headlamps are switched on or the light switch is in position **(A)**.



Press the fog light button in the centre of the light switch.

Q The warning light in the instrument cluster and the light in the switch both illuminate.

i *NOTE: With the light switch in position (A) and the rear fog lights switched on, the dipped beam headlamps will also switch on irrespective of ambient light conditions. When the rear fog lamps are switched off, the dipped beam headlamps will also switch off dependant on ambient light conditions.*

BEFORE YOU DRIVE

LIGHTING

Direction indicators



Push the direction indicator/main beam stalk downwards **(1)** to switch on the left-hand direction indicator.

Push the direction indicator/main beam stalk upwards **(2)** to switch on the right-hand direction indicator.



The corresponding warning light in the instrument cluster will flash.

The stalk returns to its rest position as the steering wheel returns to its central position.

Direction indicators - lane change

Move the direction indicator/main beam stalk until resistance is felt when changing lanes on a motorway. The appropriate direction indicator flashes three times.

For further information about the lighting see Light switch, page 1.49.

Hazard warning lamps

The hazard warning lamps operate even if the ignition is switched off. As a safety feature, they switch on automatically when an air bag is triggered.

Operating the hazard warning lamps



1. Press the hazard warning lamps button.
2. All the direction indicator lamps and both direction indicator warning lights in the instrument cluster flash.
3. Press the hazard warning lamps button again to switch off.

BEFORE YOU DRIVE

LIGHTING

i *NOTE: If the hazard warning lamps have been switched on automatically, press the hazard warning lamps button once to switch them off.*

Panic alarm

The panic alarm function is designed to attract attention by sounding the horn and flashing the direction indicator lamps repeatedly.

The panic alarm can be switched on by pressing the hazard warning lamps button for a period of 3 seconds or more.

The horn will cease after the panic alarm has been active for a long period of time, but the direction indicator lamps will continue to flash. The horn can be re-initiated by pressing the hazard warning lamps button for a period of 3 seconds or more.

To switch the panic alarm off, press the hazard warning lamps button briefly.

Parking lights



i *NOTE: The parking lights can only be activated when the ignition is switched off.*

1. To activate the parking lights, press the direction indicator/main beam stalk down for the left-hand side or push up for the right-hand side until resistance is felt. The selected parking lights will illuminate once the vehicle has been locked.

2. To deactivate the parking lights, press the direction indicator/main beam stalk down for the left-hand side or push up for the right-hand side until resistance is felt. The selected parking lights will then be deactivated.

i *NOTE: This will allow parking lights on both sides to be active at same time, and also allows one side to be deactivated, whilst keeping the opposite side activated.*

Windscreen wiper



1. Windscreen wiper off
2. Automatic wiper
3. Slow wiper
4. Fast wiper

i *NOTE: Switch off the windscreen wiper in dry weather, dirt can cause inadvertent wiper sweeps which could damage the wiper blade or windscreen.*

Operating the windscreen wiper

1. Ensure the ignition is switched on.
2. Move the wiper stalk to the required position

i *NOTE: If the windscreen wiper is switched on and the vehicle comes to a halt, the windscreen wiper automatically switches to intermittent wipe, until the vehicle moves away.*

Automatic wiper

A rain sensor, located on the windscreen behind the rear view mirror, measures the quantity of water on the screen and operates the wiper at the most appropriate speed.

To select, move the windscreen wiper stalk to the automatic wiper position **(2)**.

The wiper will wipe once. The wipe frequency then depends on how wet the windscreen is.

Only select the automatic wiper position in damp weather conditions or when it is raining.

To adjust the sensitivity of the rain sensor, see Wiper Sensitivity, page 3.16.

Slow wiper

Move the wiper stalk to position **(3)**, to operate the wiper at slow speed.

Return the stalk to position **(1)** to switch off.

Fast wiper

Move the wiper stalk to position **(4)**, to operate the wiper at fast speed.

Return the stalk to position **(1)** to switch off.

BEFORE YOU DRIVE

WASHERS AND WIPER

Single wipe



1. For a slow single wipe, briefly push the wiper stalk and release. The wiper will operate once at slow speed, without washers.
2. For a fast single wipe, push and hold the wiper stalk down. The windscreen wiper will perform a continuous fast wipe until the stalk is released.

Windscreen wash/wipe



Pull the wiper stalk towards you.

The windscreen washers and wiper will operate at a slow speed for as long as the stalk is held.

When the stalk is released, the wiper will complete its cycle and return to the parked position. After a period of time the wiper will operate once more to wipe any remaining washer fluid from the windscreen.

i *NOTE: The position of the washer jets are set during vehicle manufacture and should not need adjusting. If a problem occurs, consult your McLaren Retailer.*

BEFORE YOU DRIVE

VEHICLE LIFT*

Vehicle Lift Operation

Vehicle lift gives you the option to raise or lower the vehicle dependent on the current vehicle ride height.

Ride height can only be raised when travelling at speeds below 31 mph (50 kph). The vehicle will automatically lower at speeds above 37 mph (60 kph).

i *NOTE: If the vehicle lift icon in the right-hand display is amber, the system is not available. Do not drive the vehicle at high speed and contact your McLaren Retailer as soon as possible.*

The vehicle suspension can be left fully raised for extended periods, but it may relax to a lower level over time.

If the vehicle is left in a raised position for a long period, a system reset may occur when the engine is next started to return the vehicle to normal ride height.

If the vehicle is left in a raised position for a long period, a system reset may occur. When the vehicle is next started the ride height will return to normal.

You obtain access to vehicle lift using the menu structure, see LEFT-HAND DISPLAY, page 3.3.

Accessing the menu

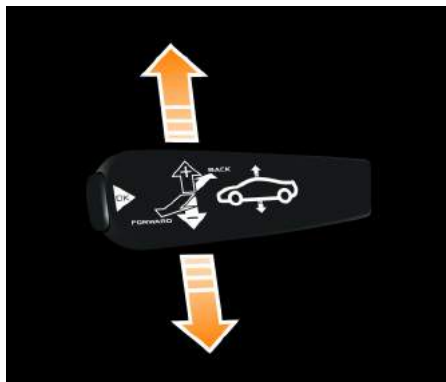

You can access the vehicle lift menu using the menu control stalk on the left of the steering column, whenever the engine is running.

i *NOTE: Vehicle handling modes are inhibited when vehicle lift is lowering or raising.*

i *NOTE: Vehicle lift will be unavailable if launch mode is active.*

Hold the menu control stalk up for one second to quickly access the menu. A confirmation tone will be heard.

Alternatively, access vehicle lift using the menu structure, see LEFT-HAND DISPLAY, page 3.3.

The left-hand display will exit after the timeout duration has been exceeded back to homescreen if there is no activity on the menu. To set the timeout to home screen duration, see Home screen, page 3.6.



STARTING AND DRIVING

Vehicle electrical status	2.2
Switching on the ignition	2.3
Instruments and warning lights	2.3
Seamless shift gearbox gear positions.....	2.6
Parking brake.....	2.8
Brake pedal.....	2.10
Starting/stopping the engine.....	2.10
Driving	2.12
Exhaust Temperature Monitoring.....	2.14
Parking Sensors*	2.14
Rear View Camera (RVC)*	2.15

SEAMLESS SHIFT GEARBOX

Overview.....	2.18
Gear positions	2.18
Accelerator pedal position	2.19
Manual/Automatic mode.....	2.19

HANDLING AND POWERTRAIN CONTROLS

Active dynamics control	2.23
Active button.....	2.23
Handling control	2.24
Powertrain control	2.26
Winter mode	2.28
Launch control	2.29
Launch control process	2.29

DRIVING SAFETY SYSTEMS

General.....	2.31
--------------	------

Anti-lock Braking System	2.31
Brake assist system.....	2.32
Brake disc wiping.....	2.32
Hill hold control.....	2.33
Brake-steer.....	2.33
Electronic brake pre-fill	2.33
Electronic Stability Control.....	2.34
Airbrake	2.36
Tyre Pressure Monitoring System*	2.40

CRUISE CONTROL

Overview	2.43
Using cruise control	2.43
Cancelling cruise control.....	2.44
Increasing cruise speed	2.45
Reducing cruise speed.....	2.45
Resuming a stored speed.....	2.46

ACTIVE SPEED LIMITER (ASL)

Setting an upper speed limit.....	2.47
-----------------------------------	------

RUNNING IN

Running in	2.48
Normal/Road use.....	2.48
Track use.....	2.49

REFUELLING

Filling with fuel.....	2.50
Recommended fuel.....	2.52

WINTER DRIVING

Winter driving.....	2.53
---------------------	------

Vehicle electrical status

The vehicle will implement one of the following statuses according to the criteria detailed.

 *NOTE: The engine can be started from any of the following states, except Locked. If the car is in Sleep mode, the START/STOP button will need to be pressed for more than two seconds.*

 *NOTE: If the vehicle detects the battery charge is getting too low, it will adopt the Awake status to conserve energy. Accessory and Ignition will be prohibited, but Crank will still be available. This is to allow the engine to be started so that battery recharging can commence.*

Locked

Vehicle is locked in low power mode.

Sleep

Vehicle is unlocked in low power mode.

Awake

Door is opened or **START/STOP** button pressed, when the car is in Sleep mode.

Time, odometer reading and battery status are available in the left-hand display. Fuel gauge operates in right-hand display.

If there is no further activity after two minutes, the vehicle will return to the Sleep status.

Accessory

START/STOP button is pressed, when car is in Awake mode.

Windows and heater/air conditioning controls operate. IRIS and instrument cluster menus are available.

If there is no further activity after 15 minutes, the vehicle will return to the Sleep status.

Accessory mode can also be entered by pressing the **OK** button on the instrument cluster menu stalk. The key must be present within the cockpit area for this function to be available.

Ignition

START/STOP button is pressed, when car is in Accessory mode.

 *NOTE: There is no time out with ignition on. Be aware that the battery could become discharged.*

Crank

See Starting/stopping the engine, page 2.10.

DRIVING CONTROLS

STARTING AND DRIVING

Switching on the ignition

1. Ensure that the key fob is inside the vehicle.



2. To switch on the ignition without starting the engine, press the **START/STOP** button, without depressing the brake pedal.

i *NOTE: If the vehicle is in Awake mode, press the START/STOP button twice.*

3. The ignition will switch on, the oil temperature, water temperature and fuel gauges will operate and several of

the warning lights will illuminate as a self-test. The instrument cluster will fully illuminate.

Instruments and warning lights

Warning lights can be divided into different categories, according to the colour that they illuminate.

- RED, AMBER or YELLOW - indicates that a fault has been detected. A fault indicated by a RED light is more important than one displayed in AMBER or YELLOW.
- BLUE or GREEN - indicates that a system or feature is switched on and operating.

Main instruments overview



1. Tachometer, page 3.2
2. Speedometer, page 3.2

Left-hand display overview







The left-hand display provides vital information to the driver as well as the facility to personalise some vehicle settings.











Use the control stalk to navigate through the menus.

Warning lights - left-hand side



	Electronic Stability Control, page 2.34
	Electronic Stability Control, page 2.34
	Brake warning light, page 2.10
	Seat belt warning light, page 1.39

	General warning - illuminates in conjunction with other warning lights
	Rear fog lamp, page 1.51
	Sidelamps, page 1.50
	Dipped beam headlamps, page 1.50
	Main beam headlamps, page 1.50
	Direction indicators, page 1.52
	Gearbox mode indicator, page 3.25
	Messages - Coupe and Spider, page 3.26

Right-hand display overview

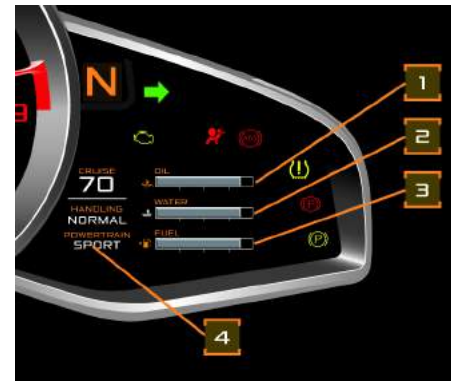

1. Oil temperature, page 3.34
2. Water temperature, page 3.35
3. Fuel level, page 3.35
4. Handling control, page 2.24
Powertrain control, page 2.26

Warning lights - right-hand side



	Direction indicators, page 1.52
	Engine warning light, page 2.13
	Supplementary Restraint System warning light, page 1.43
	Anti-lock Braking System status light, page 2.32

	Tyre Pressure Monitoring System operation, page 2.40
	Parking brake status, page 2.9
	Parking brake fault, page 2.9
	Gear position indicator
	Gear Shift Indicator (GSI) Not available in all markets, consult your McLaren Retailer.

Seamless shift gearbox gear positions



The gearbox operates in either automatic or manual mode. Automatic mode is selected unless the driver chooses manual mode, see Manual/Automatic mode, page 2.19. If manual mode is active, gear changes are made using the gearshift paddles, see Gearshift paddles, page 2.21.

i **NOTE:** The letter on each button will illuminate red to identify if the vehicle is in Drive, Neutral or Reverse.

DRIVING CONTROLS

STARTING AND DRIVING

Drive

D All seven forward gears are available. Gear changes will be automatic, unless manual mode has been selected.

When drive is selected and the brakes are released, the vehicle will begin to move slowly without any throttle use making it useful for parking manoeuvres and for moving off in queuing traffic.

Neutral

N No gear is engaged. Releasing the brakes will allow the vehicle to move freely, e.g. for pushing or towing. For more information on use of neutral for towing, see Towing for recovery, page 5.44.

Reverse

R In normal circumstances, select reverse gear when the vehicle is stationary. When carrying out parking manoeuvres that require rapid changes from drive to reverse and back again, it is possible to engage reverse or drive at speeds up to 6mph (10 kph) whilst travelling in the opposite direction.

i *NOTE: If reverse or drive is selected at speeds above 6 mph (10 kph), the transmission will engage neutral, as a self protection feature.*

When travelling at speeds below 6 mph (10 kph), neutral can be selected by pressing the 'N' button.

When reverse is selected and the brakes are released, the vehicle will begin to move slowly without any throttle use making it useful for parking manoeuvres.

Gearshift paddles



To upshift, pull the right-hand paddle towards you. To downshift pull the left-hand paddle towards you. The current gear position appears in the gear position display, see Gear position indicator, page 3.33.

i *NOTE: The single-piece paddle and central pivot enables upshifts and downshifts to be made using either paddle.*

DRIVING CONTROLS

STARTING AND DRIVING

As an alternative, upshifts can be made by pushing the left-hand paddle away from you and downshifts can be made by pushing the right-hand paddle away from you.

The gearshift paddles operate irrespective of the handling and powertrain program selected, and there is no need to release the accelerator pedal to change gear.

⚠ WARNING: For safety, in manual mode only, the vehicle will monitor engine speed and may perform an automatic gear change if necessary.

⚠ WARNING: Do not change down for additional engine braking on a slippery surface.

i NOTE: If operating the paddles in automatic mode, the gearbox will revert to automatic changes if an eight second period elapses without a gear change being made.

To immediately shift to the lowest possible gear whilst the vehicle is moving, select and hold a downshift on the paddle. The vehicle

will then go down through all gears sequentially until the optimum gear is reached or you release the paddle.

When the vehicle speed is below 6 mph (10 kph) or the vehicle is stationary with a gear selected, select a downshift and hold the paddle to select neutral.

Parking brake

⚠ WARNING: Do not place small items such as coins in the parking brake recess as this could inhibit the operation of the parking brake switch.

i NOTE: When parking on steep downhill slopes, turn the front wheels towards the kerb. When parking on steep uphill slopes, turn the front wheels away from the kerb.



Parking brake status

 Pull the parking brake switch upwards to apply. The bar in the parking brake switch and the red parking brake applied status light in the instrument cluster illuminates.

If the parking brake applied status light is flashing, the parking brake has failed to engage/disengage. To resolve, engage/disengage the parking brake again. The bar in the parking brake switch will always show the same state as the parking brake applied status light.

Parking brake fault

 If there is a malfunction with the parking brake, the yellow parking brake malfunction status light in the instrument cluster illuminates and the bar in the parking brake switch flashes. Contact your McLaren Retailer as soon as possible.

Parking brake operation





 Keep the brake pedal depressed, and press the parking brake switch downwards to disengage. The bar in the parking brake switch and the red parking brake applied status light in the instrument cluster extinguishes.

 **WARNING: If the parking brake is manually released, the vehicle may start to move.**

 **NOTE:** If the parking brake is not manually released, it will automatically release as the vehicle is driven off forward, or in reverse as long as the following conditions are met:

- all doors are closed
- driver's seat belt is buckled

 **NOTE:** It is only possible to disengage the parking brake with the ignition on. The parking brake can be applied in all ignition states, including car asleep.

 **NOTE:** In the event of total footbrake failure, the parking brake can be applied when the vehicle is moving to slow the vehicle.

Brake pedal

 **WARNING:** Do not keep any objects in the driver's footwell. Ensure that floor mats or carpets are properly secured and do not obstruct the pedals.

If objects become trapped between the pedals, you would not be able to brake or accelerate, and this could lead to an accident.

 **WARNING:** The braking system is servo assisted when the engine is running. The brakes will still function with the engine off, but more pressure will be required to operate them.

 **WARNING:** Do not rest your foot on the brake pedal while travelling as this may overheat the brakes, reduce their efficiency and cause excessive wear.

 **WARNING:** If the brake warning light illuminates while the vehicle is in motion, stop the vehicle as soon as safety permits and contact your McLaren Retailer immediately.

Brake discs and pads

 **WARNING:** New brake pads require a period of bedding in. For the first 625 miles (1,000 km), avoid situations where heavy braking is required.

Brake disc and pad wear depends on the driving style and driving conditions.

Brake warning light

 The brake warning light will illuminate when the ignition is switched on as a system test. If the brake warning light illuminates at any other time, a fault is indicated. Stop the vehicle as soon as safety permits and contact your McLaren Retailer immediately.

Starting/stopping the engine

 **WARNING:** Never run the engine when the vehicle is in an enclosed space. Exhaust fumes contain poisonous carbon monoxide. Breathing exhaust fumes could lead to unconsciousness and death.

 **NOTE:** Do not depress the accelerator pedal when starting the engine.

The engine can be either started using manual cranking or timed cranking.

To change between the cranking functions of the **START/STOP** button, see Timed Crank, page 3.14.

Manual cranking

1. Ensure that the key fob is in the vehicle.



2. Depress the brake pedal, and continuously press the **START/STOP** button, the engine will start.
3. Cranking can be stopped by either releasing the brake pedal, or releasing the **START/STOP** button.

Timed cranking

1. Ensure that the key fob is in the vehicle.



2. Depress the brake pedal, press and release the **START/STOP** button and the engine will start.
3. If the **START/STOP** button is pressed again while the engine is cranking, cranking is stopped.

Stopping the engine

 **WARNING: The gearbox has no Park position to lock the gears. The parking brake is the only means of preventing the vehicle moving.**

 **NOTE:** Do not depress the accelerator pedal when stopping the engine.

Do not switch the engine off immediately after high speed/high load running. Allow it to run for 2 minutes so the engine temperature returns to normal.

 **NOTE:** When parking on steep downhill slopes, turn the front wheels towards the kerb. When parking on steep uphill slopes, turn the front wheels away from the kerb.

1. Pull the parking brake switch upwards to apply.

 **NOTE:** If the parking brake is not applied manually, it will apply automatically when the engine is not running, and the driver's door is open. Automatic

application can be overridden by holding the parking brake switch in the down position whilst opening the driver's door.

2. Select neutral.



3. Press the **START/STOP** button. The engine stops, the vehicle enters the Accessory state, see Vehicle electrical status, page 2.2. The immobiliser is activated.

i **NOTE:** If the START/STOP button is pressed for more than a second, the vehicle will enter the Awake state for a brief time before returning to Accessory state if no further inputs are made, see Vehicle electrical status, page 2.2.

Driving

Driving away

⚠ **WARNING:** Never turn the engine off while driving, there will be no assistance for the steering or the foot brake. You will need more effort to steer and brake and could lose control of the vehicle and cause an accident.

i **NOTE:** Do not drive at high engine speeds until the engine has reached normal operating temperature.

i **NOTE:** The doors will lock when the vehicle reaches a speed of approximately 9 mph (15 kph). Auto lock can be set in the instrument cluster, see Auto Door Lock, page 3.14.

🌱 **ENVIRONMENTAL:** When starting from cold, gear changes occur at higher engine speeds. The catalytic converter will reach its operating temperature quicker and reduce engine emissions.

1. With the engine running, press and hold the brake pedal.

2. Select drive or reverse gear, or initiate an upshift by operating the gearshift paddles. For more information, see Gearshift paddles, page 2.21 and Gear positions, page 2.18.
3. Keep the brake pedal depressed and release the parking brake switch. The red status light in the instrument cluster and the bar in the parking brake switch extinguish.



WARNING: If the parking brake is manually released, the vehicle may start to move.



NOTE: If the parking brake is not manually released, it will automatically release as the vehicle is driven off forward, or in reverse as long as the following conditions are met:

- all doors are closed
- driver's seat belt is buckled

4. Carefully depress the accelerator pedal.

Engine warning light



This engine warning light illuminates when the ignition is on and extinguishes as soon as the engine is started, provided no faults exist.

If the light illuminates while driving, an engine management fault has been detected and reduced engine performance may be experienced. Stop the vehicle as soon as safety permits and contact your McLaren Retailer immediately.

Limphome mode

Limphome mode activates automatically when vehicle systems detect a fault which may cause further damage unless vehicle or system performance is restricted. Care should be taken while driving in this mode. Contact your McLaren Retailer immediately.

Economical driving

Improved fuel economy can be achieved by following this advice.

- Accelerate smoothly and gently from a standing start.

- When in manual mode, avoid high engine rpm by changing to a higher gear as soon as possible.



The Gear Shift Indicator (GSI) will illuminate when an upshift would maintain optimum economy.



NOTE: Not available in all markets, consult your McLaren Retailer.

- Avoid labouring or over-revving the engine.
- Switch off the air conditioning when it is not needed.
- Avoid journeys where frequent stop start driving is involved.
- Ensure that your driving style suits the prevailing road and traffic conditions; allow time for smooth, progressive acceleration and braking.
- Use a reputable fuel economy tracking website to track your mileage and fuel usage.

DRIVING CONTROLS

STARTING AND DRIVING

Exhaust Temperature Monitoring

The vehicle continuously monitors exhaust temperatures to protect the catalytic converters from damage caused by overheating.

If excessive exhaust temperatures are measured, a warning will be displayed on the left-hand side of the instrument cluster.

The vehicle speed should be reduced as soon as this message is observed. Refrain from manoeuvres involving high engine speed and high engine load (full throttle) to allow the exhausts to cool. The message will remain until the temperature has reduced.

If the exhaust temperature remains at an excessive level, a second warning is displayed and Limphome mode is activated. The engine performance will remain limited until the vehicle is restarted.

i *NOTE: Catalytic converter over temperature warnings are not likely to be observed during normal driving and are the result of extreme operating conditions. For example, high exhaust temperatures can be caused by extended track driving, maintaining high*

engine speed for long durations, and sudden and repeated changes in throttle demand.

i *NOTE: High exhaust temperatures can cause damage to catalytic converters and should be avoided by practicing careful driving.*

If the warnings persist, contact your McLaren Retailer.

Parking Sensors*



The parking sensors alert the driver to any obstructions while manoeuvring at low speeds. The system comprises four ultrasonic sensors in the front bumper, four ultrasonic sensors in the rear bumper and two sounders. Each sounder has a different pitch to indicate whether the obstruction is at the front or the rear of the vehicle.

The front parking sensors are automatically switched on when the ignition is switched on. The rear parking sensors are switched on when reverse gear is selected. The light

around the parking sensors button will illuminate red to indicate that parking sensors are active.

The centre sensors on the front bumper have a range of approximately 1 metre (3 feet). The centre sensors in the rear bumper have a range of approximately 1.5 metres (5 feet).

An intermittent tone is heard when an obstruction is within range. As the vehicle moves closer to an obstruction, the frequency of the tone increases. When the distance between the sensors and the obstruction is less than approximately 40 centimetres (1.5 feet), the tone becomes continuous.

⚠ WARNING: The parking sensors may not detect moving objects such as children and animals, until they are dangerously close. Always manoeuvre with caution and always use your mirrors turn your head and look behind you.

i *NOTE: The parking sensors are for guidance only and are not intended to replace the driver's visual checks for obstructions when manoeuvring. The parking sensors may not detect some obstructions, such as narrow posts or small obstructions close to the ground such as kerbs.*

The rear parking sensors are automatically switched off when reverse gear is de-selected.

The parking sensors can be switched off manually by pressing the centre of the button, the light around the button will extinguish.

When the system has been manually switched off, both the front and rear sensors will still switch on when reverse gear is selected and remain on until manually switched off again.

If a fault is detected, a long high-pitched tone will sound. If the sensors are obscured by dirt, ice or snow, clean them. If the problem persists, contact your McLaren Retailer.

Rear View Camera (RVC)*

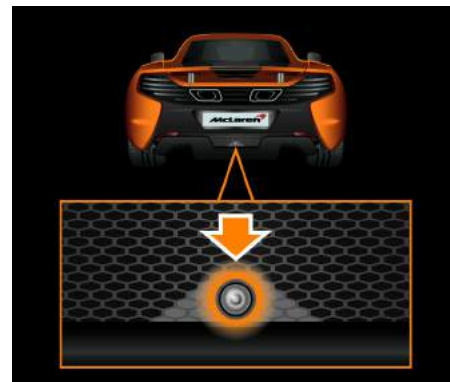

The Rear View Camera (RVC) is mounted in the centre of the rear grille. The live video feed is displayed on the IRIS screen when the function is active.

i *NOTE: If the video feed is blurred or unclear, carefully clean the lens with water and a soft cloth.*

DRIVING CONTROLS

STARTING AND DRIVING



A coloured grid is overlaid onto the live video feed as a guide to the proximity of visible objects to the rear bumper of the vehicle.

Each coloured box starts at the rear of the vehicle and extends 25 centimetres (10 inches) beyond the widest point of the vehicle and extends back, away from the vehicle.

The red static box extends back 40 centimetres (1.5 feet) from the rear of the vehicle.

The green static box extends back 2 metres (6.6 feet) from the rear of the vehicle, with an additional line at 1 metre (3.3 feet).

The yellow dynamic box extends back 3 metres (10 feet) from the rear of the vehicle, with additional lines at 2 metres (6.6 feet) and 1 metre (3.3 feet). The yellow box will curve, in relation to steering angle, indicating the current path of the vehicle.

i *NOTE: The rear view camera is for guidance only and is not intended to replace the driver's visual checks for obstructions when manoeuvring. The rear view camera may not show some obstructions in certain ambient light or weather conditions.*

i *NOTE: The steering guide grid will not be displayed if a steering angle fault exists.*

The RVC is automatically activated when reverse gear is selected and automatically deactivated 10 seconds after a forward gear is selected or immediately if the vehicle's forward speed exceeds 6 mph (10 kph).

Following automatic activation, notifications can be accessed by touching the status bar. Close the notification to return to the RVC screen. If the screen is touched anywhere below the status bar or any of the physical IRIS buttons are pressed, RVC will be minimised, but remain active. Touch the RVC banner in the status area to reactivate the RVC.

While minimised, the RVC will be automatically deactivated 10 seconds after a forward gear is selected or immediately if the vehicle speed exceeds 6 mph (10 kph).



The RVC can be manually deactivated by touching the on-screen icon.

DRIVING CONTROLS

STARTING AND DRIVING

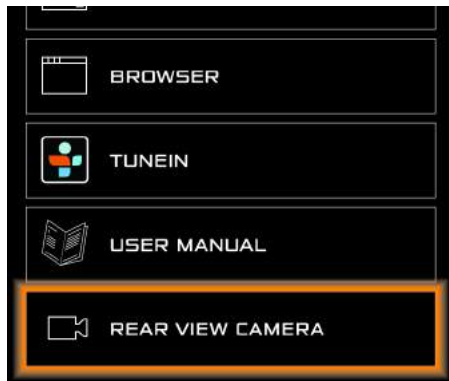

The RVC can be manually activated by selecting REAR CAMERA from the IRIS APPS screen.

 When the RVC has been manually activated, it can be deactivated by touching the on-screen icon. The RVC will also be deactivated if the screen is touched anywhere below the status bar or any of the physical IRIS buttons are pressed.

DRIVING CONTROLS

SEAMLESS SHIFT GEARBOX

Overview

The gearbox is a 7-speed, dual clutch Seamless Shift Gearbox that can be operated in automatic or manual mode.

Automatic mode is selected unless the driver chooses manual mode, see Manual/Automatic mode, page 2.19.

In automatic mode, the Gearbox automatically optimises the shift points to suit your style of driving by selecting the most appropriate gear depending on:

- Powertrain control, page 2.26
- Accelerator pedal position, page 2.19
- Vehicle speed
- Braking effort

i **NOTE:** Allow the engine and gearbox to warm up before driving at high engine speeds and high loads.

Avoid prolonged spinning of the rear wheels when driving on slippery surfaces as this could damage the drivetrain.

Gear positions

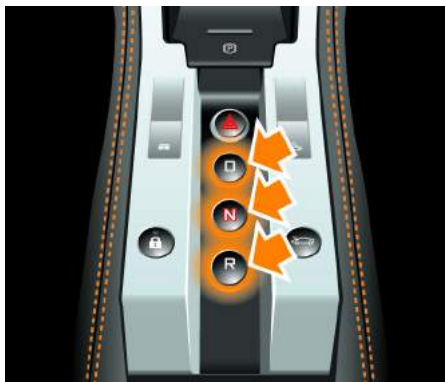

Press one of the gear position buttons.

i **NOTE:** The letter on each button will illuminate red to identify if the vehicle is in Drive, Neutral or Reverse.

Drive

i All seven forward gears are available. Gear changes will be automatic, unless manual mode has been selected.

When drive is selected and the brakes are released, the vehicle will begin to move slowly without any throttle use making it useful for parking manoeuvres and for moving off in queuing traffic.

Neutral

i No gear is engaged. Releasing the brakes will allow the vehicle to move freely, e.g. for pushing or towing. For more information on use of neutral for towing, see Towing for recovery, page 5.44.

Reverse

i In normal circumstances, select reverse gear when the vehicle is stationary. When carrying out parking manoeuvres that require rapid changes from drive to reverse and back again, it is possible to engage reverse or drive at speeds up to 6mph (10 kph) whilst travelling in the opposite direction.

i **NOTE:** If reverse or drive is selected at speeds above 6 mph (10 kph), the transmission will engage neutral, as a self protection feature.

DRIVING CONTROLS

SEAMLESS SHIFT GEARBOX

When travelling at speeds below 6 mph (10 kph), neutral can be selected by pressing the 'N' button.

When reverse is selected and the brakes are released, the vehicle will begin to move slowly without any throttle use making it useful for parking manoeuvres.



The gear (manual mode) or the gear position (automatic mode) selected will be shown in the instrument cluster.

Accelerator pedal position

Your style of driving influences how the Seamless Shift Gearbox changes gear.

With light accelerator pedal use, upshifts are made at lower engine speeds. With firmer accelerator pedal use, upshifts are made at higher engine speeds.

Kickdown

Kickdown is designed to achieve immediate acceleration.

Depress the accelerator pedal fully beyond the pressure point, a click will be felt through the pedal. The gearbox will downshift immediately to the lowest appropriate gear, and maximum acceleration will follow. Once the pedal pressure is released, kickdown will cease and normal gear changes will resume.

i *NOTE: Moderate accelerator pedal pressure may also cause the gearbox to downshift, depending on vehicle speed.*

Manual/Automatic mode

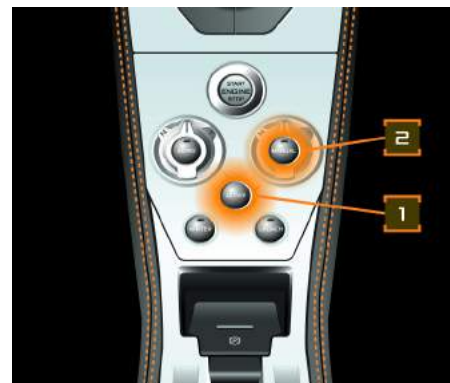

Press the **ACTIVE** button (1) to switch on the active dynamics panel.

The halo around the ACTIVE button will come on. When selecting the different drive modes, their respective button will become illuminated. You can deactivate your drive mode selection at any time by pressing the **ACTIVE** button again. Press the **MANUAL** button (2) to select manual mode.

DRIVING CONTROLS

SEAMLESS SHIFT GEARBOX

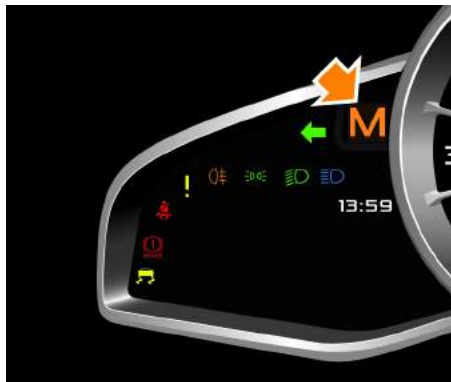

The gearbox mode indicator displays **M**. All forward gear changes are made by operating the gearshift paddles, see Gearshift paddles, page 2.21.



When driving in manual mode, the gear position indicator will change from orange to red to indicate that an upshift is required to maintain optimum performance.



When in manual mode and driving more economically the Gear Shift Indicator (GSI) will illuminate when an upshift would maintain optimum economy. The GSI will not illuminate if the requested acceleration or deceleration cannot be met with a higher gear. See Economical driving, page 2.13.

i *NOTE: Not available in all markets, consult your McLaren Retailer.*

Press the **MANUAL** button again to revert to automatic mode.



The gearbox mode indicator displays **A**. All gear changes occur automatically, but if a gearshift paddle is operated the gearbox will adopt a temporary manual mode. This mode will remain active for as long as the driver continues to make manual gear changes, each within an eight second period. The gearbox mode indicator displays **A/M**, see Gearbox mode indicator, page 3.25.

i *NOTE: As soon as an eight second period has elapsed without a manual gear change being made, the gearbox will revert to automatic mode.*

Gearshift paddles



To upshift, pull the right-hand paddle towards you. To downshift pull the left-hand paddle towards you. The current gear position appears in the gear position display, see Gear position indicator, page 3.33.

i *NOTE: The single-piece paddle and central pivot enables upshifts and downshifts to be made using either paddle.*

As an alternative, upshifts can be made by pushing the left-hand paddle away from you and downshifts can be made by pushing the right-hand paddle away from you.

The gearshift paddles operate irrespective of the handling and powertrain program selected, and there is no need to release the accelerator pedal to change gear.

⚠ **WARNING: For safety, in manual mode only, the vehicle will monitor engine speed and may perform an automatic gear change if necessary.**

⚠ **WARNING: Do not change down for additional engine braking on a slippery surface.**

i *NOTE: If operating the paddles in automatic mode, the gearbox will revert to automatic changes if an eight second period elapses without a gear change being made.*

DRIVING CONTROLS

SEAMLESS SHIFT GEARBOX

To immediately shift to the lowest possible gear whilst the vehicle is moving, select and hold a downshift on the paddle. The vehicle will then go down through all gears sequentially until the optimum gear is reached or you release the paddle.

When the vehicle speed is below 6 mph (10 kph) or the vehicle is stationary with a gear selected, select a downshift and hold the paddle to select neutral.

If under 6mph (10 kph) you can also press the neutral button on the tunnel to go into neutral.

Pre-cog



WARNING: Do not allow this feature to distract you from the prevailing road and traffic conditions.

It is possible to pre-select the next gear change using the 'pre-cog' feature, to enable a faster gear change. 'Pre-cog' (or 'pre-cognition') means 'foreknowledge'.

The paddles have two switching points. Pull and hold the appropriate paddle to the first point, this informs the gearbox of an impending gear change. The gearbox then prepares for that change by pre-selecting the next gear. When the change is required, pull the paddle fully and the gear change will be performed almost instantaneously.

Active dynamics control

The handling and powertrain control switches, on the active dynamics panel, allow the driver to change the handling and performance characteristics of the vehicle.

Active dynamics panel

The active dynamics panel contains the following controls, and will only function with the engine running or the ignition switched on.

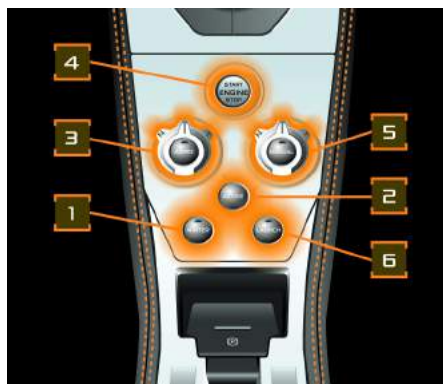

1. Winter mode, page 2.28
2. Active button, page 2.23
3. Handling control, page 2.24
4. STOP/START button
5. Powertrain control, page 2.26
6. Launch control, page 2.29

Active button



Pressing the **ACTIVE** button activates the handling and powertrain controls. The **ACTIVE** button and handling and powertrain switches will illuminate.

i **NOTE:** When the ignition is switched off, the controls on the active dynamics panel will also switch off. The handling and powertrain control settings will be remembered but it will be necessary to press the **ACTIVE** button again to

DRIVING CONTROLS

HANDLING AND POWERTRAIN CONTROLS

operate the controls when the ignition is next switched on or the vehicle will revert to automatic gear changes.

Handling control

The handling control switch affects the following vehicle characteristics:

- Roll stiffness
- Adaptive damping
- ESC settings
- Steering response

Selecting a setting



1. Press the **ACTIVE** button to switch on the active dynamics panel.



2. Rotate the handling control to select one of the following settings.

Settings

N	Normal	Suspension at its softest setting, offers a compliant ride while maintaining good body control through corners.
S	Sport	Suspension is stiffer, giving a firmer ride coupled with enhanced handling characteristics. Active aerodynamics (Airbrake) becomes available to further enhance vehicle handling.
T	Track	The suspension is at its stiffest, giving almost race car handling and ride characteristics. Active aerodynamics (Airbrake) becomes available to further enhance vehicle handling. The Electronic Stability Control warning light is permanently illuminated.

The mode selected will remain active, until the selection is changed, or the ignition is switched off.

i *NOTE: If all the following conditions are not met when the selection is made, the mode will not be implemented until they are met:*

- engine running with no fault conditions existing
- no vehicle dynamic or stability interventions activated, e.g. Electronic Stability Control;
- vehicle speed below 114 mph (190 kph)
- steering wheel in straight ahead position, and not being turned, if the car is moving

When the active dynamics panel is off, the Handling display in the right-hand display will show Normal, see Handling and powertrain display, page 3.33.

i *NOTE: In Track handling mode, the Electronic Stability Control system is still in operation. For further information, see Electronic Stability Control, page 2.34.*

Proactive chassis control

The Proactive chassis control system features adjustable roll control using hydraulically interconnected dampers, in place of the typical mechanical anti-roll bars. Each handling mode adjusts the settings of the dampers to offer high levels of roll control, grip, traction and a unique combination of ride comfort and handling.

Powertrain control

Selecting a setting



1. Press the **ACTIVE** button to switch on the active dynamics panel.



2. Rotate the powertrain control to select one of the following settings.

Settings

N	Normal	Gear changes are configured to offer the optimum economy without sacrificing the vehicle's inherent performance.
S	Sport	Gear changes will occur at a higher engine speed and with a reduced shift duration and are further enhanced with cylinder cut. See Cylinder cut, page 6.12.
T	Track	Gear change strategy is at its sharpest. Changes occur instantly, according to throttle response and are further enhanced with cylinder cut and inertia push. See Cylinder cut, page 6.12 and Inertia push, page 6.13.

The different gear change strategies outlined above are only relevant with automatic mode selected.

DRIVING CONTROLS

HANDLING AND POWERTRAIN CONTROLS

The mode selected will remain active, until the selection is changed, or the ignition is switched off.

When the active dynamics panel is off, the Powertrain display in the right-hand display will show Normal, see Handling and powertrain display, page 3.33.

i *NOTE: The use of the Track setting on the public road is not recommended. The Track setting is strictly intended for high performance track/off road use only.*

Economy mode



When the vehicle is operating in any powertrain setting with automatic gear shifts selected, the transmission adapts to an economical shift strategy during periods of gentle driving. This is determined by the vehicle speed, acceleration, braking and road gradient.

Depending on the current active shift strategy, the word 'NORMAL', 'SPORT' or 'TRACK' changes colour from white to green. For information on other ways to save fuel, see Economical driving, page 2.13.

DRIVING CONTROLS

HANDLING AND POWERTRAIN CONTROLS

Winter mode

Selecting Winter mode



1. Press the **ACTIVE** button to switch on the active dynamics panel.



2. Press the **WINTER** button, the button will illuminate and WINTER will appear in the Powertrain and Handling display.

3. Winter mode overrides both handling and powertrain controls. In winter mode, the roll stiffness, adaptive damping and Electronic Stability Control settings are changed to give the maximum assistance to the driver in slippery conditions. The engine speed, gearshift points and shift speed are also optimised for the slippery conditions.
4. For more information, see Winter driving, page 2.53.
5. To switch off, press the **WINTER** button again, alternatively switch off the ignition.

Launch control

Launch control is designed to offer the maximum acceleration from a standing start.

WARNING: Do not initiate launch control unless on a track. Before initiating launch control, ensure that all doors, luggage compartment and engine cover are closed, and the prevailing conditions are suitable for performing maximum acceleration manoeuvres.

i NOTE: Launch control can be operated in either automatic or manual modes and any handling or powertrain mode, but only when the active dynamics panel is activated.

i NOTE: The launch sequence can be aborted at any point by carrying out any of the following actions:

- applying the parking brake
- pressing the ACTIVE button to switch off the vehicle dynamics panel
- or pressing the launch button to switch off launch control

i NOTE: If there is a fault or the launch procedure has not been followed correctly, a warning message *Launch mode unavailable* - see Owners Manual will be shown in the left-hand display. Repeat the launch procedure, ensuring that it is followed correctly. If the warning message remains, contact your McLaren Retailer.

- i** NOTE: Launch mode is only available if the following conditions are met:
- both doors are closed
 - the vehicle lift function is inactive
 - atmospheric altitude has no detrimental effect with respect to engine performance
 - winter mode not activated
 - engine coolant at normal operating temperature

Launch control process

1. Ensure the steering wheel is in a straight ahead position.
2. Depress the brake pedal firmly with your left foot and select first gear.



3. Press the **ACTIVE** button to switch on the active dynamics panel.

DRIVING CONTROLS

HANDLING AND POWERTRAIN CONTROLS



4. Press the **LAUNCH** button.

i *NOTE: L will flash in the gearbox mode indicator, see Manual/Automatic mode, page 2.19 and 'Launch Mode Active - Awaiting Throttle' will be shown in the left-hand display.*

5. With your left foot remaining on the brake pedal, press and hold the accelerator pedal down fully with your right foot, the engine speed will increase to 3,000 rpm.

i *NOTE: To abort launch control release the brake pedal before pressing the accelerator pedal or wait for approximately 60 seconds until launch control is deactivated.*

i *NOTE: The message 'Launch Mode Active - Boost Building' will be shown in the left-hand display. Once sufficient boost has been achieved, the message 'Launch Mode Active - Boost Ready' will be shown in the left-hand display.*

6. Release the brake pedal with your left foot and the launch control system will perform a launch start to give maximum acceleration.

i *NOTE: To abort launch control release the accelerator pedal or wait for approximately 5-10 seconds until launch control is deactivated. If the launch is aborted, release the accelerator pedal and then press again to drive away.*

7. Launch control will operate if procedure has been followed correctly until aborted.

i *NOTE: Whilst in launch control, the vehicle will carry out automatic gear shifts, and optimise traction. It will continue to do so until launch control is aborted. To abort launch control, release the accelerator pedal, apply the brake, or operate one of the gearshift paddles.*

General

This section contains information about the following safety systems:

- Anti-lock Braking System
- Brake assist system
- Brake disc wiping
- Hill hold
- Brake-steer
- Electronic brake pre-fill
- Electronic Stability Control
- Airbrake

 **WARNING: The risk of an accident increases when driving quickly, especially when cornering, on wet and icy roads. Always maintain a safe distance to the vehicle in front.**

The driving safety systems described in this section are unable to override the laws of physics.

Always adapt your driving style to suit the road and weather conditions and maintain a sufficient distance from other road users and objects on the road.

 **NOTE:** *In winter conditions, the maximum effect of the Anti-lock Braking System, brake assist system and Electronic Stability Control can only be achieved if you use winter tyres, with snow chains where they are necessary.*

Anti-lock Braking System

The Anti-lock Braking System prevents the wheels from locking when you brake. This allows the vehicle to be steered during braking manoeuvres.

The Anti-lock Braking System works from a speed of approximately 5 mph (8 kph) upwards, regardless of road surface conditions. It works on slippery surfaces, even when you brake gently.

 **WARNING: Do not depress the brake pedal repeatedly in quick succession (pumping). Depress the brake pedal firmly and evenly. Pumping the brake pedal reduces the braking effect.**

If the Anti-lock Braking System operates during braking, the warning light flashes, and the brake pedal pulses as this happens.

When the Anti-lock Braking System is activated, maintain the force on the brake pedal until the braking situation is over.

 **WARNING: Always adapt your driving style to suit the prevailing road and weather conditions and maintain sufficient distance from other road users and objects on the road.**

Anti-lock Braking System status light



If there is a malfunction with the system, the status light will illuminate. Do not drive your vehicle, contact your McLaren Retailer as soon as possible.

 **WARNING: If the Anti-lock Braking System malfunctions, brake assist system and Electronic Stability Control are also deactivated.**

If the Anti-lock Braking System malfunctions, the wheels could lock when you brake. This may increase the stopping distance and impair your ability to steer.

Brake assist system

Brake assist system operates in emergency braking situations. If you depress the brake pedal quickly, the brake assist system automatically increases the force applied to the brakes and thus shortens the stopping distance.

Continue to depress the brake pedal firmly until the emergency situation is over, the Anti-lock Braking System prevents the wheels from locking.

When you release the brake pedal, the brakes will work as normal. Brake assist system is deactivated.

 **WARNING: If the brake assist system malfunctions, the brakes will still operate. However, the braking force is not automatically boosted and this may increase the stopping distance.**

Brake disc wiping

Brake disc wiping operates automatically when the windscreen wiper is switched on. It prevents moisture build up on the brake discs during periods of heavy rain, improving braking performance.

Hill hold control

If the brake pedal is applied to hold the vehicle on a hill, this function will continue to apply the brakes for two seconds after the pedal is released to assist a smooth start.

Brake-steer

Brake steer offers the benefits of a torque vectoring differential, but is integrated into the braking system reducing weight and providing excellent speed of response.

Torque vectoring gives the differential the ability to change the amount of power that is sent to each of the rear wheels to provide optimum stability and traction.

If the system detects that the car is starting to understeer through a corner, the inside rear brake is gently applied. This helps to increase the yaw rate of the car, making the car feel more resistant to understeer. The lateral 'g' force is also increased giving better handling characteristics.

If the driver uses too much throttle exiting a corner, the inside rear wheel increases speed, which without brake steer could cause the car to become unstable. In this situation, brake steer will again gently apply the brake on the inside rear wheel, thereby restoring traction and stability.

Electronic brake pre-fill

If the accelerator pedal is suddenly released, the electronic brake pre-fill function immediately brings the brake pads into contact with the discs, ensuring rapid braking.

Electronic Stability Control

Electronic stability control monitors driving stability and traction between the tyres and the road surface.

Electronic stability control detects when a wheel starts to spin or the vehicle starts to skid and stabilises the vehicle by braking individual wheels, and/or limiting the engine power output. This also assists when pulling away on wet or slippery road surfaces and stabilises the vehicle when braking.



Electronic stability control operation is indicated by the warning light blinking on and off.

i *NOTE: The electronic stability control warning light is permanently illuminated when Track mode is selected on the Handling Control.*

! **WARNING: If the electronic stability control warning light blinks on and off, do not deactivate Electronic Stability Control. Adapt your driving style to suit road and traffic conditions.**

Electronic stability control cannot reduce the risk of an accident if you drive too fast. Electronic stability control is unable to override the laws of physics.

i *NOTE: Electronic stability control only functions properly if wheels with the recommended specification tyres are used.*

Electronic stability control is activated automatically as soon as the engine is running.

Traction control system

The traction control system is an integral part of Electronic Stability Control.

The traction control system reduces engine torque to prevent the wheels from spinning. If additional intervention is required to stop the wheels from spinning, the vehicle will apply the rear brakes individually. The traction control system brakes individual drive wheels to prevent them from spinning. This means that the vehicle can accelerate on slippery surfaces.



WARNING: The traction control system cannot reduce the risk of an accident if you drive too fast. The traction control system is unable to override the laws of physics.

Deactivating Electronic Stability Control



WARNING: When Electronic Stability Control is deactivated, the risk of the vehicle skidding is increased. Adapt your driving style to suit road and traffic conditions.



WARNING: Do not deactivate Electronic Stability Control unless on a track and prevailing conditions are suitable.



NOTE: When you deactivate Electronic Stability Control, the following conditions result:

- the 'ESC OFF' warning light illuminates
- Electronic Stability Control no longer improves driving stability
- the engine's torque is no longer limited and the drive wheels could spin

- *the anti-lock braking system remains activated*
1. Ensure the vehicle is stationary, with the engine running and the brake pedal depressed.
 2. Track powertrain and handling modes should be selected, but the dynamics panel should not be switched on, see Handling control, page 2.24.



3. Press and hold the **ACTIVE** button on the active dynamics panel for 5 seconds, a warning message will be displayed in the left-hand display 'Confirm ESC Off'.



4. To confirm the selection, press and hold the **AERO** and **MANUAL** buttons together for 5 seconds.
5. The Electronic Stability Control OFF warning light illuminates and a confirmation message appears in the left-hand display.

Reactivating Electronic Stability Control



Perform any of the following to reactivate Electronic Stability Control:

- Press the **ACTIVE** button on the active dynamics panel.
- Change the setting on either the handling or powertrain control.
- Switch on cruise control.
- Switch the ignition off and then switch on again.

The Electronic Stability Control OFF warning light in the instrument cluster goes out, and Electronic Stability Control is reactivated.

- i** *NOTE: Electronic Stability Control is automatically reactivated when the ignition is next switched off and on again.*

Airbrake

⚠ WARNING: The driver is responsible for ensuring that no persons, or any part of their body can be trapped during Airbrake movement.

The Airbrake is located at the rear of your McLaren and has three operating positions, as described below, and a self-test facility that initiates after every full ignition on/off cycle.

- i** *NOTE: The Airbrake uses hydraulic pressure and will only operate with the engine running.*
- i** *NOTE: The Airbrake system is automatically deactivated at temperatures below -4°C (24°F) or at engine speeds below 500 rpm. A warning message will appear on the instrument cluster if operation of the Airbrake is selected. The Airbrake system will become active when the ambient temperature rises above -4°C (24°F), or engine speed rises above 500 rpm.*



1. Normal driving position
2. Downforce position
3. Rapid braking position

Self-test

After each full ignition cycle, the first time the engine is started and at speeds above 9 mph (15 kph), the Airbrake self-tests, rising to the downforce position and then returning slowly to its initial position.

WARNING: If the Airbrake fails the self-test, a message will appear in the left-hand display. Contact your McLaren Retailer.

NOTE: If the engine has been stopped with the Airbrake in the downforce position, the self-test procedure will be reversed, i.e. the Airbrake will lower fully then raise to the driver selected downforce position.

Normal driving position mode

This is the default position with the active dynamics panel switched off and is used for normal driving conditions.

Downforce position

In this position, the Airbrake is raised to increase rear downforce. This position enhances vehicle stability with increased aerodynamic drag. The Airbrake can be raised at any vehicle speed.



1. Press the **ACTIVE** button to switch on the active dynamics panel.



2. Press the **AERO** button. The Airbrake rises and locks in the downforce position.

i **NOTE:** The Airbrake may automatically lower to reduce aerodynamic drag in favour of straight line speed if the vehicle is travelling in a straight line at full throttle.

The Airbrake will not automatically lower when cornering or when launch control is active.

Lowering the Airbrake - vehicle moving

If the car is travelling at speeds above 9 mph (15 kph), press the **AERO** button, and the Airbrake will lower to the normal driving position.

⚠ **WARNING:** Before deactivating the downforce position, check the Airbrake for any objects which may obstruct movement, e.g. branches or leaves, and remove them or the Airbrake may no longer function correctly. The driver is responsible for ensuring no person or object can be trapped during Airbrake movement.

i **NOTE:** The Airbrake will only lower if the speed of the vehicle meets the following criteria:

- When cornering, the vehicle speed must be between 9 mph (15 kph) and 75 mph (120 kph).
- When travelling in a straight line, the vehicle speed must be between 9 mph (15 kph) and 155 mph (250 kph).
- This is to reduce the risk of any object being trapped.

Lowering the Airbrake - vehicle stationary

If the car is being parked and the Airbrake is still deployed, press and hold the **AERO** button for 5 seconds, and the Airbrake will start to lower. Keep the button pressed until the Airbrake is fully lowered, remaining alert to any potential obstructions.

⚠ **WARNING:** Before lowering, check the Airbrake for any objects which may obstruct movement, e.g. branches or leaves, and remove them or the Airbrake may no longer function correctly. The driver is responsible for ensuring no person or object can be trapped during Airbrake movement.

i **NOTE:** If the AERO button is released before the Airbrake is fully retracted, it will return to the previously selected position.

Rapid braking position

During hard braking at speeds above 60 mph (95 kph), the Airbrake automatically rises to the fully deployed position to provide maximum braking assistance.

Once the pressure on the brake pedal is released, the Airbrake will return to its previous position - either the driver's selected downforce position or the normal driving position.

i *NOTE: The Airbrake will lower just before the vehicle comes to a halt during hard braking.*

The Airbrake may actively deploy, even if the brake pedal is not depressed, to maintain vehicle stability under the following conditions:

- When high longitudinal G forces are measured, for example, when the accelerator pedal is suddenly released.
- When high vertical G forces are measured, for example, when travelling over the crest of a hill.

i *NOTE: The Airbrake will only actively deploy if Sport or Track handling mode is selected and launch control is not active.*

! **WARNING: When activated, the Airbrake will temporarily block the view through the interior mirror. In this case, monitor the traffic behind you through the exterior mirrors.**

Manual test



1. Press the **ACTIVE** button to switch on the active dynamics panel.
2. Press the **AERO** button. The Airbrake rises and locks in the downforce position.
3. Press and hold the **AERO** button to return the Airbrake to its rest position.

Tyre Pressure Monitoring System*

Prior to every time the vehicle is to be driven, each tyre should be checked when cold and inflated/deflated to the inflation pressure recommended by the vehicle manufacturer on the vehicle placard or tyre inflation pressure label. (If your vehicle has tyres of a different size than the size indicated on the vehicle placard or tyre inflation pressure label, you should determine the proper inflation pressure for those tyres).

In certain circumstances it is possible that the TPMS pressure warning will display without the loss of air from the tyre. This may be due to temperature variations between the locations where the tyre pressure was set and where the vehicle is driven. For example setting pressures in an air conditioned or heated garage and then driving the vehicle outside may induce a tyre pressure warning after a short period of driving. The warning may also display when extreme ambient temperature variations occur or during seasonal temperature changes.



WARNING: Never ignore a tyre pressure warning. Check tyre pressures immediately and if necessary contact your McLaren retailer.

Tyre Pressure Monitoring System overview



The Tyre Pressure Monitoring System warns you when the pressure drops or the temperature increases above an acceptable level in one or more of the tyres.

The system monitors the tyre pressures and temperatures in each wheel using sensors located in each tyre valve and a receiver located within the vehicle. Communication between the sensors and the receiver is via Radio Frequency (RF) signals.



NOTE: The Tyre Pressure Monitoring System can suffer interference if you are operating radio transmitting equipment (e.g. radio headphones, two-way radios) in or near the vehicle.

Tyre Pressure Monitoring System operation



If a low tyre pressure is detected, the Tyre Pressure Monitoring System warning light will illuminate along with an associated error message in the left-hand display.

Stop the vehicle as soon as possible, check all your tyres and inflate them to the recommended pressure, see Tyre pressures, page 5.34. The warning light will extinguish once the tyres have been inflated to the correct pressure.

Driving on a significantly under-inflated tyre causes the tyre to overheat and can lead to tyre failure. Under-inflation also reduces fuel efficiency and tyre tread life, and may affect the vehicle's handling and stopping ability.

WARNING: TPMS is not a substitute for proper tyre maintenance, and it is the driver's responsibility to maintain correct tyre pressure, even if under-inflation has not reached the level to trigger illumination of the TPMS low tyre pressure warning light.

Each tyre should be checked weekly when cold and inflated/deflated to the inflation pressure recommended on the tyre inflation pressure label.

Navigate through the 'Vehicle Info' screen in the left-hand display to view the current tyre pressures, see Vehicle info, page 3.17.

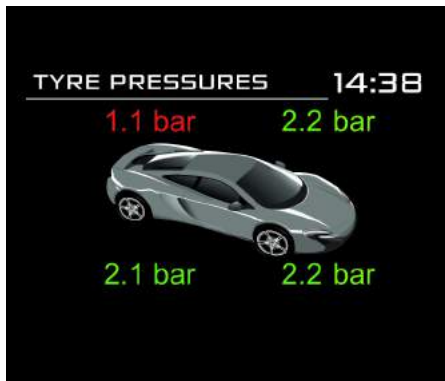

The display shows the pressures of each of the four tyres. If the pressure figure appears in green, no action is required. If it appears as red text, inflate the associated tyre to the correct pressure as soon as possible.

Inspect the tyre(s) for any possible causes of reduced tyre pressure.

WARNING: The tyre pressures indicated in the left-hand display will be more accurate with a pressure gauge. The Tyre Pressure Monitoring System is not a substitute for

manually checking tyre pressures or checking for wear and damage. The system only provides a low tyre pressure warning and does not re-inflate the tyres.

The Tyre Pressure Monitoring System cannot alert you to damage to a tyre. Regularly check the condition of your tyres.

WARNING: If low pressure warnings occur frequently, have the tyres checked at your McLaren Retailer. Driving on an under-inflated tyre will cause the tyre to overheat and can lead to tyre failure.

ENVIRONMENTAL: Under-inflated tyres reduce fuel efficiency and tyre tread life, and may affect the vehicle's handling and braking characteristics.

ENVIRONMENTAL: Check tyre pressures at least every 7 days.

DRIVING CONTROLS

DRIVING SAFETY SYSTEMS

Tyre Temperature Monitoring System operation

If a high tyre temperature is detected, the Tyre Temperature Monitoring System will display an error message in the left-hand display.

Navigate through the 'Vehicle Info' screen in the left-hand display to view the current tyre temperatures, see Vehicle info, page 3.17.

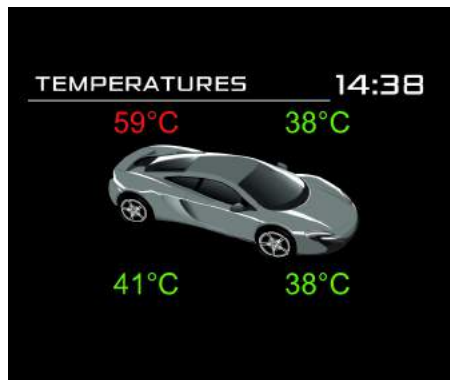

This shows the current temperature of each of the four tyres. If the temperature figure appears in green, no action is required. If it

appears as red text, the safe operating temperature of the tyres has been exceeded. Reduce speed or stop the vehicle until the temperatures are at a safe level, i.e. temperatures are displayed in green.

Inspect the tyre(s) for any possible causes of increased tyre temperature.

Overview

WARNING: Pay particular attention to road and traffic conditions, when cruise control is activated, and always travel at a speed which is safe for the current conditions.

Never use cruise control on winding or slippery roads or when visibility is poor, e.g. in fog, heavy rain or snow.

Cruise control allows the driver to maintain a constant speed without using the accelerator pedal. This is useful on motorway journeys where a constant speed can be maintained for long periods.



All cruise control functions are operated by the cruise control stalk, positioned on the right of the steering column.

Using cruise control



Accelerate to the desired speed and push the stalk up briefly, to activate cruise control. The set speed will appear in the right-hand display.

i *NOTE: Cruise control will only operate at speeds in excess of 20 mph (30 kph).*

Speed can be increased at any time by pressing the accelerator pedal. Once the accelerator pedal is released the vehicle will return to the cruise speed.

WARNING: Always be aware that cruise is engaged and do not override cruise for extended periods. Releasing the accelerator in these circumstances could lead to the vehicle not decelerating at the rate you expect.

Cancelling cruise control

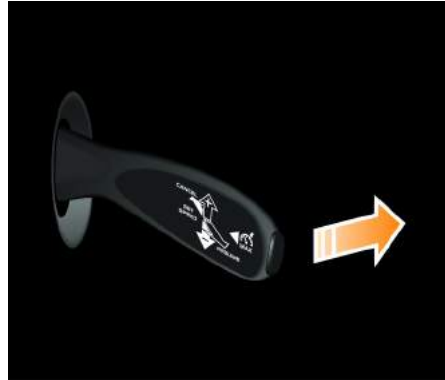

Briefly press the cruise control stalk away from you.

Cruise control is cancelled. The indicator in the instrument cluster extinguishes but the last speed set remains stored.

NOTE: The last speed stored is cleared when you switch off the engine.

Cruise control is also cancelled if the foot brake is pressed, if neutral is selected or if Active Speed Limiter is selected.

NOTE: Cruise control is cancelled automatically if Electronic Stability Control detects wheel spin or vehicle skid or if Electronic Stability Control is switched off.

Increasing cruise speed



- A brief press of the stalk upwards will increase the vehicle speed in 1 mph (1 kph) increments (depending on the units selected, see Units, page 3.7);
- or press and hold the stalk upwards until the desired speed is reached, then release the stalk;
- or accelerate to the new desired speed and push the stalk up.

Reducing cruise speed



- A brief press of the stalk downwards will decrease the vehicle speed in 1 mph (1 kph) decrements (depending on the units selected, see Units, page 3.7);
- or press and hold the stalk downwards, the vehicle will decelerate, release the stalk when the desired speed has been reached.

i *NOTE: If you decelerate using the cruise control stalk, the gearbox may shift down to increase the rate of deceleration.*

Downshifting manually using the gear change paddles will not disengage cruise control.

DRIVING CONTROLS

CRUISE CONTROL

Resuming a stored speed

⚠ WARNING: Only resume the stored speed if it is appropriate for the current road and traffic conditions. Sudden acceleration could endanger yourself and others.



Pull the cruise control stalk briefly towards you.

Cruise control will adjust the vehicle's speed to the last speed stored.

DRIVING CONTROLS

ACTIVE SPEED LIMITER (ASL)

Setting an upper speed limit

 **WARNING:** It is the driver's responsibility to keep within proper speed limits.

 **WARNING:** The ASL feature may allow the vehicle to exceed the upper speed limit in certain situations, for example when descending steep gradients.

 **NOTE:** ASL can be activated when the car is stationary. The upper speed limit will be set to a default speed of 20 mph (30 kph).

The ASL control allows the driver to set an upper speed limit.

Selecting a speed

1. Press the button on the end of the cruise control stalk, to select ASL mode.
2. Accelerate or decelerate the vehicle to the maximum permitted speed.



3. Push the stalk up briefly to select the desired ASL upper speed limit.



4. The upper speed limit appears in the right-hand display.

Running in

Observe the following running in instructions when the vehicle is new or if any of these components have been replaced.

Engine and gearbox

For the first 625 miles (1,000 km):

- drive at varying road and engine speeds
- do not drive faster than the maximum speed limit of the road, or 150 mph (240 kph)
- do not use your vehicle on a race track;
- avoid heavy loads on the engine (driving at full throttle)
- avoid driving at engine speeds less than 2,000 rpm
- avoid running at constant speed and load for long periods
- avoid using kickdown
- do not downshift for additional engine braking
- avoid stopping the engine within 2 minutes of high speed and high load running
- avoid idling the engine for more than 10 minutes

After the 625 miles (1,000 km) running in period, you may gradually use the vehicle's full performance.

 **NOTE:** Failure to observe the engine and gearbox operating limits during the running in period may lead to premature wear or damage.

 **NOTE:** These running in instructions also apply for the first 625 miles (1,000 km) after the engine or transmission has been replaced.

 **ENVIRONMENTAL:** This advice will assist in improving fuel economy and should be adopted as normal driving practice even after the running in period.

Brakes

New brakes require an initial bedding in period. Avoid heavy braking situations for the first 625 miles (1,000 km).

Normal/Road use

- Allow the engine to warm up before driving at high engine speeds and high loads. Limit engine speed to 5,000 rpm until the engine reaches full operating temperature.
- Avoid stopping the engine within 2 minutes of high speed/high load running.
- Avoid idling the engine for more than 10 minutes.

Track use



NOTE: Do not use the vehicle on a track during the running in period.

Before you use your vehicle on the track, consult your McLaren Retailer. McLaren recommend that your vehicle is inspected before and after track use.

DRIVING CONTROLS

REFUELLING

Filling with fuel

⚠ WARNING: Fuel is highly flammable. Fire, naked flames, smoking and using a mobile telephone are prohibited when handling fuels. Switch off the engine before refuelling.

⚠ WARNING: Fuel and fuel vapours can damage your health. Do not inhale fuel vapours or allow fuel to come into contact with skin or clothing.

The fuel filler flap is located at the rear on the left-hand side. It is locked or unlocked automatically when the vehicle is locked or unlocked.

i NOTE: Do not attempt to force the filler flap open if the car is locked. You may damage the flap and its locking mechanism.

i NOTE: The fuel filler flap will remain locked if the engine is running.

Filling on the forecourt

1. Switch off the engine.

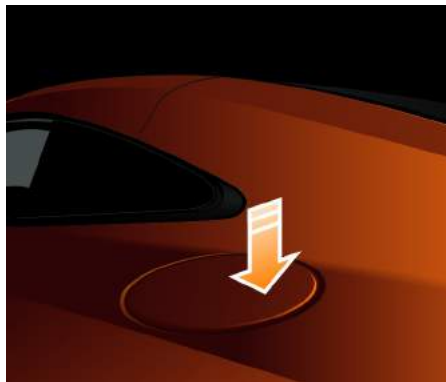

2. Press the rear edge of the fuel filler flap, the latch will release.
3. Open the flap.

i NOTE: Your vehicle is not fitted with a fuel filler cap.

4. Insert the nozzle into the fuel filler and dispense fuel. For fuel recommendations, see Recommended fuel, page 2.52.
5. Do not continue to fill the tank after the pump nozzle switches off.
6. Remove the nozzle.

7. Close the fuel filler flap, you will hear the latch engage.

Filling with the fuel funnel

i NOTE: The fuel funnel should only be used when filling the fuel tank from sources other than a forecourt fuel pump.

1. Switch off the engine.

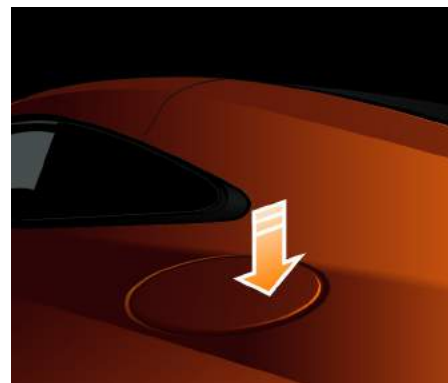

2. Press the rear edge of the fuel filler flap, the latch will release.
3. Open the flap.

i *NOTE: Your vehicle is not fitted with a fuel filler cap.*



4. Collect the fuel funnel from the luggage compartment, see Fuel funnel, page 5.12.
5. Insert the fuel funnel fully into the filler neck.
6. Insert the nozzle into the fuel funnel and dispense fuel. For fuel recommendations, see Recommended fuel, page 2.52.
7. Do not overfill.

! **WARNING: Take care to avoid spillages and overfilling. Ensure any spillages are cleaned immediately.**

8. Remove the nozzle.
9. Remove the fuel funnel, clean thoroughly and store in the luggage compartment.
10. Close the fuel filler flap, you will hear the latch engage.

DRIVING CONTROLS

REFUELLING

Recommended fuel

For maximum engine performance the use of 98 RON/88 MON unleaded petrol meeting specification EN 228 is required.

In areas where 98 RON/88 MON is unavailable, use unleaded premium grade petrol with a minimum octane rating of 95 RON/85 MON, meeting specification EN 228.

 *NOTE: Information relating to the quality of fuel being dispensed is displayed on the filling pump.*

 *NOTE: The likelihood of engine wear or damage is increased if fuel does not meet the requirements of EN 228 for unleaded petrol or if fuel additives are used.*

Damage caused by use of incorrect fuel is not covered by the vehicle warranty.

 *NOTE: This vehicle is not suitable for use with fuels containing more than 10% Ethanol.*

Do not use E85 fuels (85% Ethanol content). This vehicle is not fitted with the equipment necessary for the use of fuels containing more than 10% Ethanol. If E85 fuels are used, serious damage will occur to the engine and fuel system.

Winter driving

It is recommended that you have your vehicle inspected at your McLaren Retailer at the onset of winter. This service includes the following:

- checking the antifreeze/anti-corrosion concentration
- adding concentrated cleaning agent to the windscreen cleaning system
- checking the battery
- changing the tyres

Select Winter mode on the active dynamics panel, when conditions make it necessary, see Winter mode, page 2.28.

Winter tyres

Use winter tyres below 7°C (45°F) and on snow or ice-covered roads. The maximum effect of the Anti-lock Braking System and Electronic Stability Control systems is only achieved with these tyres.

Use winter tyres of the same make and tread on all wheels to maintain safe handling characteristics. Change the tyre type in 'Vehicle Settings' in the left-hand display, see Tyre Type, page 3.16.

Winter tyres are directional, not asymmetrical, and so must be fitted in accordance with the directional markings on the sides of the tyres.

 **NOTE:** Only winter tyres specified by McLaren should be used.

 **WARNING:** Replace winter tyres with a tread depth of less than 4 mm immediately. They are not suitable for winter use because they do not provide sufficient grip, and could cause an accident.

 **NOTE:** A wheel change must be carried out at your McLaren Retailer. The vehicle could be damaged if it is jacked up incorrectly.

Consult your McLaren Retailer for advice and information regarding the maximum speed specified for the winter tyres fitted. Restrict the maximum speed of the vehicle using the ASL system, see Setting an upper speed limit, page 2.47.

Snow chains

McLaren recommends that you only use snow chains which have been approved for McLaren vehicles. If you are intending to fit snow chains, bear the following points in mind:

- Only ever fit snow chains to both rear wheels.
- Comply with the manufacturer's installation instructions.

 **NOTE:** If snow chains are fitted on the front wheels, they may come into contact with the bodywork or axle components while the vehicle is being driven. As a result, the tyre or the vehicle could be damaged.

Do not exceed the maximum permissible speed of 30 mph (50 kph). Remove the snow chains as soon as possible if you are no longer driving on snow-covered roads.



OVERVIEW

Overview.....	3.2
Tachometer	3.2
Speedometer	3.2

LEFT-HAND DISPLAY

Overview.....	3.3
Home screen	3.6
Settings.....	3.7
Vehicle info.....	3.17
Language	3.20
Trip computer	3.21
Vehicle lift*	3.22
Time display	3.25
Gearbox mode indicator	3.25
Messages - Coupe and Spider.....	3.26
Messages - Spider Only	3.30

RIGHT-HAND DISPLAY

Gear position indicator	3.33
Display window	3.33
Handling and powertrain display.....	3.33
Oil temperature.....	3.34
Water temperature.....	3.35
Fuel level.....	3.35

Overview

The instruments are activated when the ignition is switched on, see Switching on the ignition, page 2.3.

WARNING: No messages will be displayed if there is a malfunction in the instruments and/or one of the displays.

The vehicle's handling characteristics may be affected. Contact your McLaren Retailer immediately.

Tachometer



The tachometer (1) is mounted centrally within the instrument cluster. The red band in the display indicates the engine's maximum RPM.

i NOTE: Do not operate the engine at or near its maximum speed for a significant length of time. The fuel supply is cut off to protect the engine when the maximum RPM is reached.

Speedometer



The speedometer (2) is a digital display mounted within the tachometer.

i NOTE: The speedometer changes from mph to kph when the units are changed from miles to kilometres, see Units, page 3.7

INSTRUMENTS

LEFT-HAND DISPLAY

Overview

The left-hand display automatically presents the information and warning messages to the driver, as and when the computer determines it is required. Serious faults are also stored in the display and presented every time the ignition is switched on. Additional engine related warning messages will be displayed when the engine is switched on. These warnings messages will be repeated until the fault has been rectified.

The stored messages can be viewed at any time when the ignition is on, see Error messages, page 3.18.

WARNING: Operating and browsing menus whilst the vehicle is in motion could make you unable to observe road and traffic conditions and could cause an accident.

WARNING: Do not ignore warning messages, failure to take appropriate action may result in injury or damage to the vehicle.

In addition to presenting vital information to the driver, the left-hand display also provides the facility to personalise some vehicle settings and enables operation of the Trip features.



Navigation through the menu structure is achieved using the control stalk mounted on the left of the steering column.

INSTRUMENTS

LEFT-HAND DISPLAY

The following categories are available.

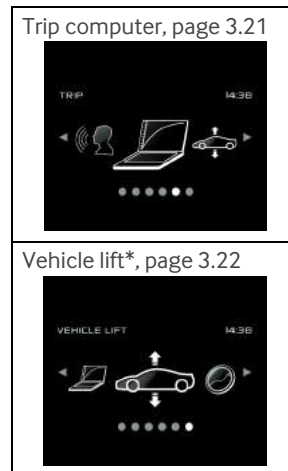
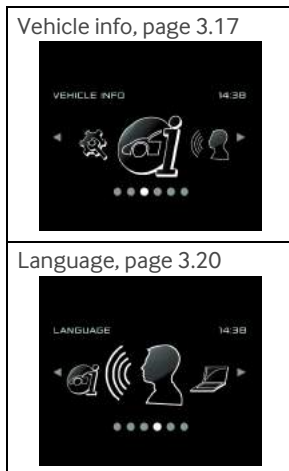
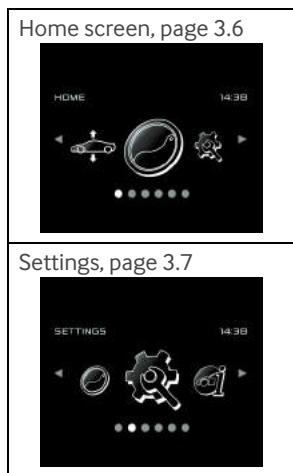

INSTRUMENTS

LEFT-HAND DISPLAY

To navigate through a category

1. Move the control stalk up or down (**SCROLL + or -**) to highlight your choice.
2. Pull the stalk towards you (**FORWARD**) to enter your selection.
3. Then select the topic of interest from the list, move the control stalk up or down (**SCROLL + or -**) to highlight your choice.
4. Pull the stalk towards you (**FORWARD**) to move through to the next menu in the structure.
5. At the end of each structure there will be a display of information or a screen where a setting can be changed
6. When the function required is selected or a setting is made, press **OK** on the end of the control stalk to confirm.
A setting is only changed if the **OK** button is pressed.

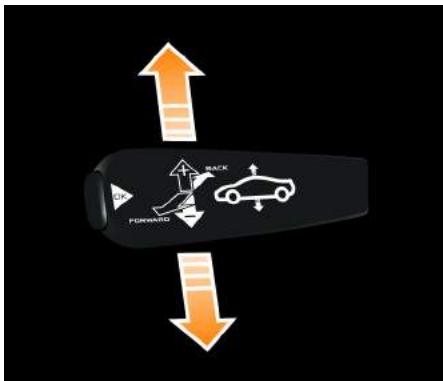

INSTRUMENTS

LEFT-HAND DISPLAY

Home screen

To change the content and layout of the Home screen, see Home screen, page 3.8.



In addition to the time, the Home Screen displays any four of the following five functions.

Odometer

The odometer displays the total distance the vehicle has travelled.

Range

Range is the estimated distance until the vehicle requires refuelling.

When refuelling is required, a range distance will no longer be shown, and a fuel pump symbol will be displayed.

Temperature

 **WARNING: Even if the temperature displayed is above freezing point, the road surface may still be icy. You should always adapt your driving style and speed to suit the weather conditions.**

Temperature is the current outside temperature. There is a short delay before a change in outside temperature is displayed.

When the outside air temperature falls below 3°C (37°F), the frost warning message will be displayed and the temperature reading will change colour after the message has been displayed.

When the outside temperature falls below 0°C (32°F), the ice warning will be displayed.

Trip

This displays the distance travelled since the trip meter was last reset.

Journey trip

This displays the distance travelled during the current journey.

Settings

Overview

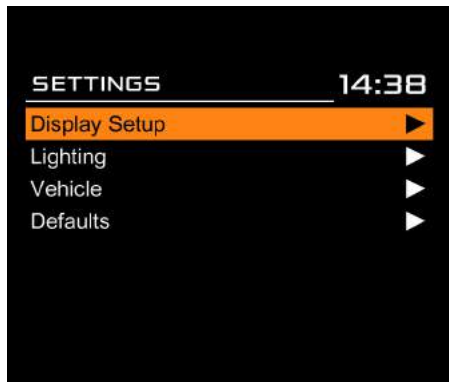

The following choices can be made from the Settings screen:

- Display setup, page 3.7
- Lighting, page 3.9
- Vehicle, page 3.10
- Defaults, page 3.17

Display setup

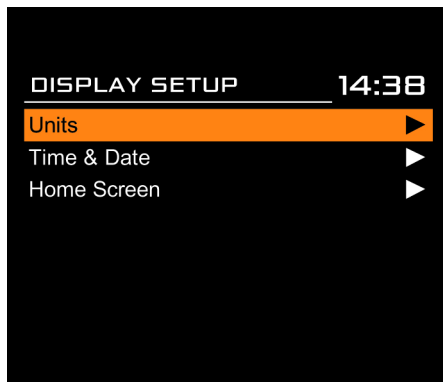

The following selections can be made from Display setup:

- Units, page 3.7
- Time and Date, page 3.8
- Home screen, page 3.8

Units

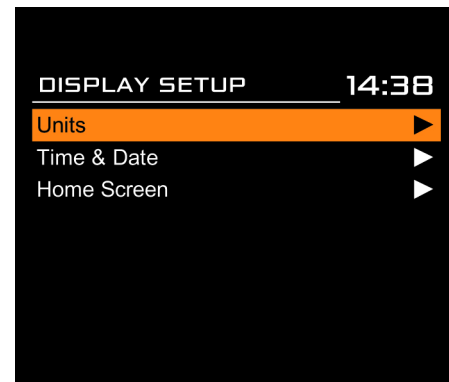

On the Units screen you can set the following units of measurement:

Distance - select miles or km

Speed - select mph or kph

Temperature - select °C or °F

Pressure - select kPa, Bar or PSI

Fuel Consumption - select mpg, km/Litre or Litres/100 km

INSTRUMENTS

LEFT-HAND DISPLAY

Volume - select UK gallons, US gallons or litres

The setting for your vehicle depends on the country or region where the vehicle was purchased. The units can be changed individually at any time.

Press the **OK** button on the end of the control stalk to confirm your selections.

 *NOTE: This feature also sets the units for the trip computer.*

Time and Date



Set the Time before setting the Date.

The time and date are both set manually.

Press the **OK** button on the end of the control stalk to confirm your choice.

 *The time display can be set as 12 hour or 24 hour format, and the date display can be set as day followed by month or month followed by day.*

Home screen



There are two choices available to you.

The first is to set four of the following five items, on the screen, in the position of your choice:

- Odometer
- Range
- Temperature
- Trip since reset
- Journey trip

INSTRUMENTS

LEFT-HAND DISPLAY

The second selection is the duration of the time out for return to the Home screen. Choose 5, 10, 30 or 60 seconds.

Press the **OK** button on the end of the control stalk to confirm your choice.

Lighting



Select External lighting, page 3.9, or Internal lighting, page 3.10.

External lighting



Two choices are available.

1. Set the duration that external lights remain on after the vehicle has been unlocked.
2. Set the duration that external lights remain on after the vehicle has been locked.

Press the **OK** button on the end of the control stalk to confirm your choice.

INSTRUMENTS

LEFT-HAND DISPLAY

Internal lighting



There are the following choices to make.

- Switch Lighting
- Footwell Lighting
- Door Lighting
- Courtesy Lighting

A bar graph will appear. Move the control stalk up or down (**SCROLL + or -**) to highlight your choice.

Press the **OK** button on the end of the control stalk to confirm your choice.

3.10

Vehicle

It is possible to make the following selections:

- Programmable Intake Sound Generator (ISG), page 3.10
- Valet Mode, page 3.13
- Auto Door Lock, page 3.14
- Auto Fold Mirrors, page 3.14
- Auto Alarm, page 3.14
- Door Unlock, page 3.14
- Timed Crank, page 3.14
- Comfort Entry/Exit*, page 3.14
- Silent Lock, page 3.15
- Reverse Mirror Dip, page 3.15
- Tyre Type, page 3.16
- Wiper Modes, page 3.16
- Wiper Sensitivity, page 3.16

Programmable Intake Sound Generator (ISG)

You can change the level of sound entering the cabin for each powertrain mode selected.

 **WARNING: Operating and browsing menus whilst the vehicle is in motion could make you unable to observe road and traffic conditions and could cause an accident.**



Three different powertrain modes will be displayed in the ISG menu.

INSTRUMENTS

LEFT-HAND DISPLAY

Select the mode that you wish to change and a bar graph showing the current ISG sound level for that mode will appear.



Move the menu control stalk up or down (**SCROLL + or -**) to achieve your preferred sound level for that powertrain mode. Press the **OK** button on the end of the menu control stalk to confirm your choice.

The default settings for each mode are as follows:

INSTRUMENTS

LEFT-HAND DISPLAY



Normal - 1 bar



Sport - 2 bars

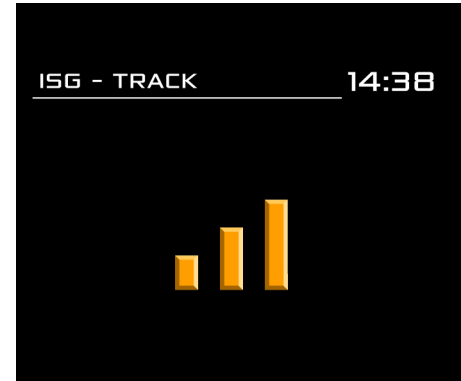

Track - 3 bars

i NOTE: These are the default settings for each mode, but you can apply any level of sound to any powertrain mode.

Valet Mode



To enter the PIN, press the control stalk up or down until the first digit appears in the display, then press the **OK** button on the end of the control stalk to confirm your choice.

Repeat the process to enter the full PIN.

The default PIN will be set to **0000**. You should change this PIN at the earliest opportunity.

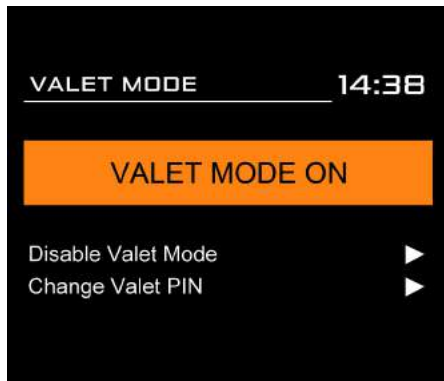

For a 5 second period after entering Valet Mode, the PIN can be changed. Select Change Valet PIN and enter a 4 digit PIN of your choice.

With Valet Mode on, the luggage compartment and engine cover both remain locked, and a confirmation message appears in the left-hand display.

When Disable Valet Mode is selected, the PIN must be entered again, before the mode is disabled.

Press the **OK** button on the end of the control stalk to confirm your choice.

INSTRUMENTS

LEFT-HAND DISPLAY

Auto Door Lock

When you receive the vehicle, Auto door lock will be set to on.

The vehicle doors will automatically lock as the vehicle moves off.

Switch Auto Door Lock off, and the doors remain unlocked after moving off, unless, they are locked manually.

Press the **OK** button on the end of the control stalk to confirm your choice.

Auto Fold Mirrors

When 'ON' is selected the exterior mirrors will fold as the vehicle is locked and unfold when the door is opened. If 'OFF' is selected, the mirrors will remain in their driving position.

Press the **OK** button on the end of the control stalk to confirm your choice.

Auto Alarm

With Auto Alarm selected, the vehicle will automatically lock and the alarm set if unlocked and left for 30 seconds with all doors and covers left fully closed.

Press the **OK** button on the end of the control stalk to confirm your choice.

Door Unlock

When 'DRIVERS' is selected, only the driver's door will unlock when the vehicle is unlocked with either the key fob or door button.

When 'BOTH' is selected, both doors will unlock when the vehicle is unlocked using either the key fob or door button.

All closures will lock with either 'DRIVERS' or 'BOTH' selected.

Press the **OK** button on the end of the control stalk to confirm your choice.

Timed Crank

With timed crank OFF, press and hold the **STOP/START** button until the engine starts.

With timed crank ON, a single press of the **STOP/START** button will cause the engine to crank until it starts.

Press the **OK** button on the end of the control stalk to confirm your choice.

Comfort Entry/Exit*

When comfort entry/exit is ON, the driver's seat will move fully rearwards and to its lowest position when the ignition is off and the driver's door is opened. Seat memory - stalk return is activated along with this option, see Seat memory - Stalk return, page 1.32.

When comfort entry/exit is OFF, the driver's seat will remain in position at all times.

Press the **OK** button on the end of the control stalk to confirm your choice.

Silent Lock

When 'ON' is selected the direction indicators are disabled when locking or unlocking using the keyless entry system.

If 'OFF' is selected, the direction indicators always flash when the car is locked or unlocked, irrespective of the method used.

All other lock and unlock features remain active.

Press the **OK** button on the end of the control stalk to confirm your choice.

Reverse Mirror Dip

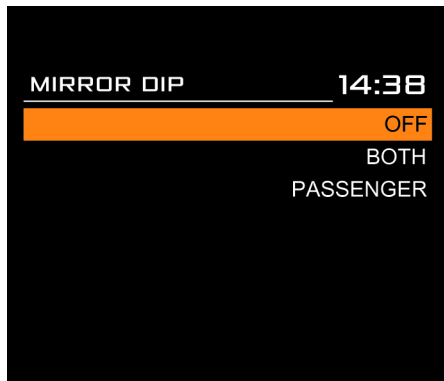

Select 'OFF', 'BOTH' or 'PASSENGER'.

'OFF' - no mirror dip will occur when reverse is engaged.

'BOTH' - both mirrors will dip when reverse is engaged.

'PASSENGER' - passenger's side mirror will dip when reverse is engaged.

Press the **OK** button on the end of the control stalk to confirm your choice.

To set the amount the mirrors will dip when reverse is selected:

1. Switch the ignition on.
2. Select 'BOTH' or 'PASSENGER' in the mirror dip section of the cluster.
3. Depress brake and select reverse gear.
4. Adjust mirror(s) to desired position, see Adjusting mirrors, page 1.47.
5. Take vehicle out of reverse.

The next time reverse is selected, the vehicle will automatically move the mirror/mirrors to the previously set offset from the normal position.

INSTRUMENTS

LEFT-HAND DISPLAY

Wiper Modes

Select either AUTOMATIC or TIMED.

With AUTOMATIC selected, wiper operation in the Auto position will be controlled by the rain sensor.

With TIMED selected, wiper operation in the Auto position will be an intermittent wipe.

Press the **OK** button on the end of the control stalk to confirm your choice.

Wiper Sensitivity



The wiper sensitivity adjusts the amount of rain present on the windscreen required to activate the wiper with AUTOMATIC mode selected. A bar graph will appear showing current wiper sensitivity setting. A higher number of bars results in a lower amount of water being required to activate this function. Move the control stalk up or down (**SCROLL + or -**) to achieve your preferred setting for the wiper operation.

Press the **OK** button on the end of the control stalk to confirm your choice.

Tyre Type



The display will show all the possible tyre types available. Select the tyres fitted to your vehicle.

Press the **OK** button on the end of the control stalk to confirm your choice.

Defaults

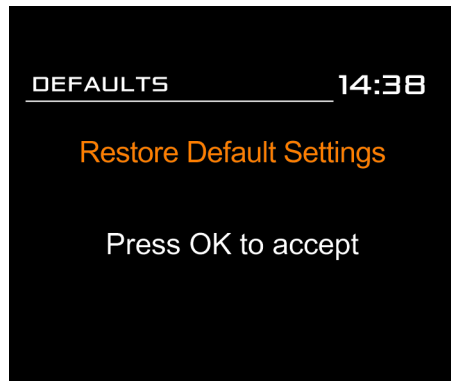

Select Restore Default Settings then press the **OK** button on the end of the control stalk to confirm that you wish to reset to the default settings.

Vehicle info

Overview

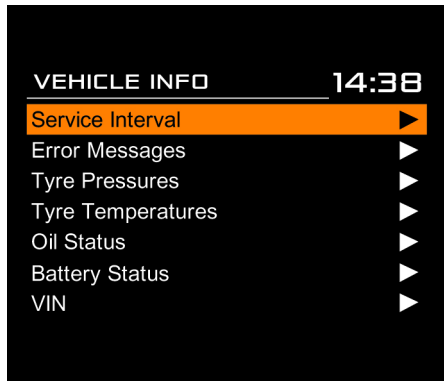

The following choices can be made from the Vehicle info screen.

- Service interval, page 3.17
- Error messages, page 3.18
- Tyre pressure monitoring, page 3.18
- Tyre temperature monitoring, page 3.18
- Oil status, page 3.19
- Battery status, page 3.19
- Vehicle identification, page 3.19

Service interval

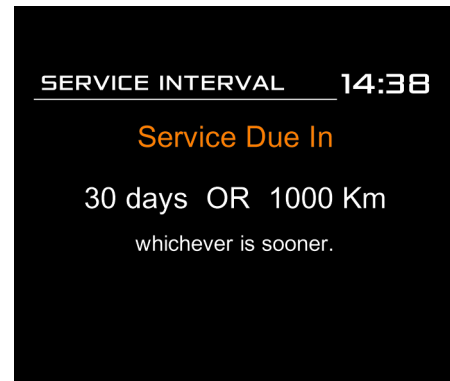

At approximately 30 days or 1,000 km (625 miles) before a service is due, the above display appears.

The message will then appear every time the ignition is switched on, with the time/distance figures reducing. Once the service has been carried out, the display will be reset by your McLaren Retailer.

If a service becomes overdue, the display will show the distance it is overdue by.

Error messages

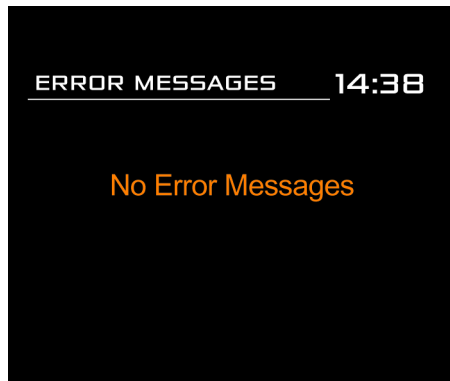

If no error messages have been logged, the display will confirm this.

If any errors have been logged, the screen will display Error Messages with arrows to scroll through the messages.

Tyre pressure monitoring

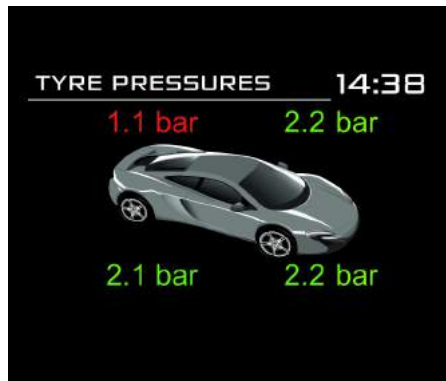

This shows the pressures of each of the 4 tyres. If the pressure figure appears in green, no action is required. If it appears as red text, have the pressure rectified as soon as possible.

Inspect the tyre(s) for any possible causes of reduced tyre pressure.

Tyre temperature monitoring

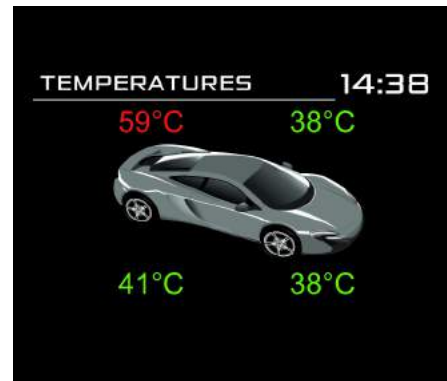

This shows the current temperature of each of the 4 tyres. If the temperature figure appears in green, no action is required. If it appears as red text, the safe operating temperature of the tyres has been exceeded. Reduce speed or stop the vehicle until the temperatures are at a safe level, i.e. temperatures are displayed in green.

Inspect the tyre(s) for any possible causes of increased tyre temperature.

INSTRUMENTS

LEFT-HAND DISPLAY

Oil status

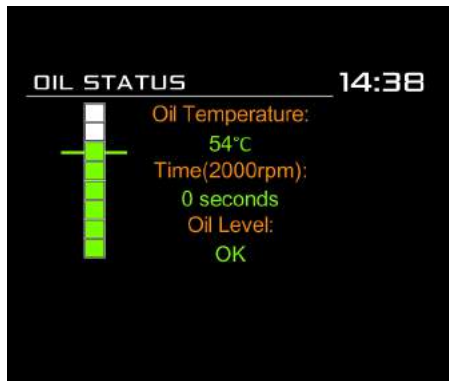

Displays a bar showing the level of oil, together with the oil temperature.

To check the engine oil level, see [Checking the engine oil](#), page 5.2

Battery status

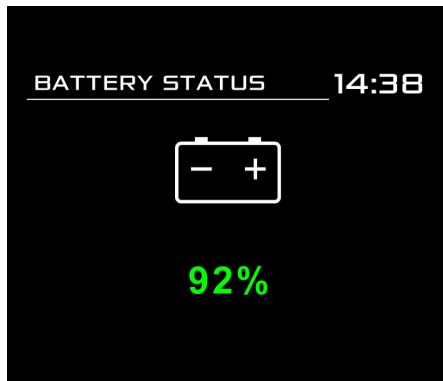

Displays a battery symbol showing the level of charge.

When battery charge is too low, a message 'Battery Fault' will also be displayed.

For more information, see [Charging the battery](#), page 5.13

Vehicle identification

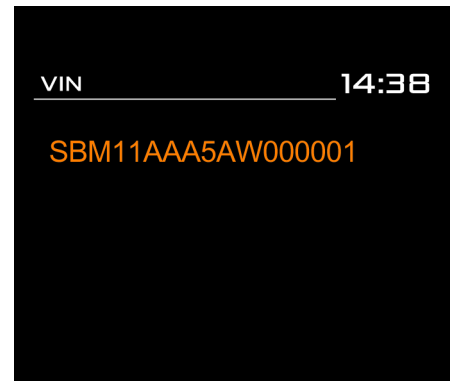

Displays the vehicle identification number.

INSTRUMENTS

LEFT-HAND DISPLAY

Language



Use this screen to set your preferred language.

The following choices are available:

- English (UK)
- English (US)
- French
- German
- Italian
- Spanish
- Chinese
- Japanese
- Russian

Press the **OK** button on the end of the control stalk to confirm your choice.

If a language is not available on your vehicle, NOT SUPPORTED will appear in the display. Consult your McLaren Retailer for further assistance.

Trip computer

The trip can display the following information.

- Trip, page 3.21
- Journey trip, page 3.21

Trip

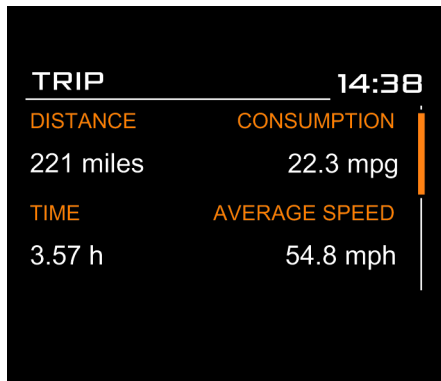

Displays distance, average fuel consumption and average speed since the last trip reset.

The hours displayed is the time that the engine has been running since the last trip reset.

Press the **OK** button on the end of the control stalk for 2 seconds to reset the information back to zero.

Journey trip



Displays distance, average fuel consumption and average speed for the current journey.

The hours displayed is the time that the engine has been running in the current journey.

The information will reset to zero when the engine is switched off.

Vehicle lift*

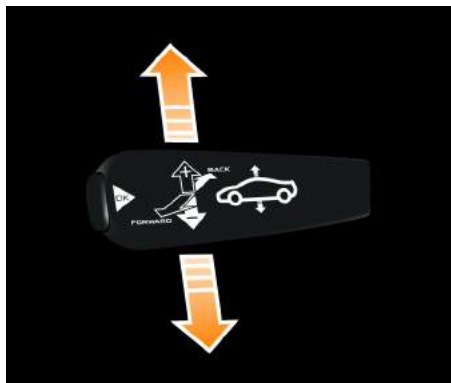

You can access the vehicle lift menu using the menu control stalk on the left of the steering column, whenever the engine is running.

i *NOTE: Vehicle handling modes are inhibited when vehicle lift is lowering or raising.*

i *NOTE: Vehicle lift will be unavailable if launch mode is active.*

Hold the menu control stalk up for one second to quickly access the menu. A confirmation tone will be heard.

Alternatively, access vehicle lift using the menu structure, see LEFT-HAND DISPLAY, page 3.3.

The left-hand display will exit after the timeout duration has been exceeded back to homescreen if there is no activity on the menu. To set the timeout to home screen duration, see Home screen, page 3.8.

i *NOTE: If the vehicle lift icon in the right-hand display is amber, the system is not available. Do not drive the vehicle at high speed and contact your McLaren Retailer as soon as possible.*

The Vehicle Lift menu displays the following Information:

- Vehicle Lift - Raise, page 3.23
- Vehicle Lift - Lower, page 3.24

A confirmation tone will be heard, when vehicle lift is selected.

Vehicle lift gives you the option to raise or lower the vehicle dependent on the current vehicle ride height.

Ride height can only be raised when travelling at speeds below 31 mph (50kph). The vehicle will automatically lower at speeds above 37mph (60kph).

i *NOTE: The vehicle suspension can be left fully raised for extended periods, but it may relax to a lower level over time.*

If the vehicle is left in a raised position for a long period, a system reset may occur when the engine is next started to return the vehicle to normal ride height.

If vehicle lift is used when in motion, slight adjustments to the steering feel may be experienced, this is normal and does not affect the operation of the vehicle.

i *NOTE: Vehicle handling modes are inhibited when vehicle lift is lowering or raising.*

i *NOTE: Vehicle lift will be unavailable if launch mode is active.*

INSTRUMENTS

LEFT-HAND DISPLAY

Vehicle Lift - Raise

- i** *NOTE: When the vehicle is at normal ride height, you will only have the option to raise the vehicle.*
- i** *NOTE: Vehicle lift will be delayed if the vehicle experiences any excessive steering wheel input.*
- i** *NOTE: Always check the vehicle lift icon in the right-hand display before driving your vehicle.*

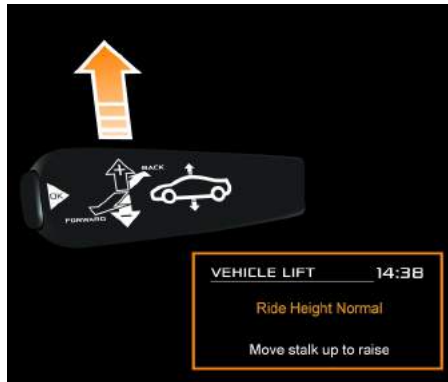

To raise the vehicle, move the menu control stalk upwards.

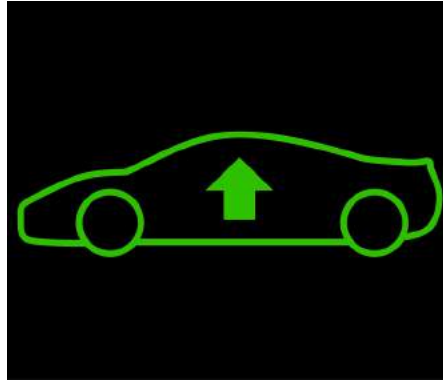

The change in vehicle height is confirmed by an ascending audible tone. 'Vehicle Raising' appears in the left-hand display and the vehicle lift icon will flash in the right-hand display.

If the engine is stopped while the vehicle is raising, the system will stop and only continue to raise when the engine is restarted.

To change from raise to lower, move the menu control stalk downwards. The vehicle will start to lower, and the information displayed on the instrument cluster will confirm the change.



When the vehicle is fully raised, an audible confirmation tone is heard. 'Ride Height: Raised' appears in the left-hand display and the vehicle lift icon is illuminated while the vehicle remains raised.

INSTRUMENTS

LEFT-HAND DISPLAY

If there is no further activity, the left-hand display will exit after the timeout duration has been exceeded back to homescreen. To set the timeout to home screen duration, see Home screen, page 3.8.

Vehicle Lift - Lower

- i** *NOTE: To lower the vehicle while stationary, the driver's door must be fully closed. Opening the driver's door will cause the vehicle to auto raise.*
- i** *NOTE: When the vehicle is raised, you will only have the option to lower the vehicle.*
- i** *NOTE: Do not drive at high speed whilst the vehicle is lowering. If the vehicle begins to auto lower, a descending audible tone is heard, and the vehicle lift menu will be displayed in the left-hand display allowing you control of the system.*
- i** *NOTE: Always check the vehicle lift icon in the right-hand display before driving your vehicle.*

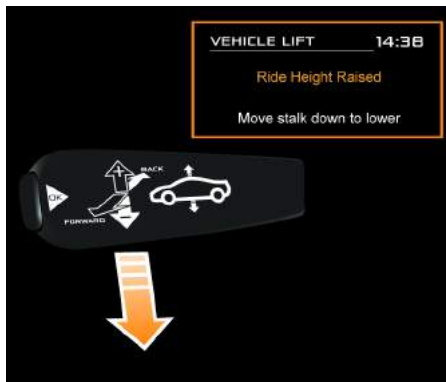

To lower the vehicle, move the menu control stalk downwards.

The change in vehicle height is confirmed by a descending audible tone. 'Vehicle Lowering' appears in the left-hand display and the vehicle lift icon will flash in the right-hand display.

To change from lower to raise, move the menu control stalk upwards. The vehicle will start to raise, and the information displayed on the instrument cluster will confirm the change.

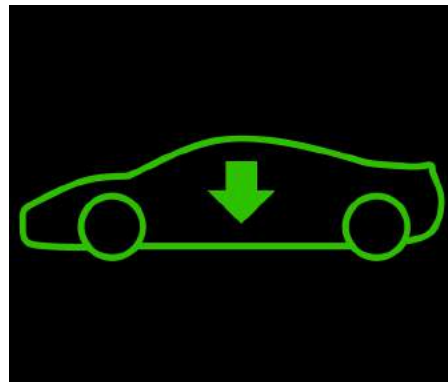

When the vehicle is lowered, an audible confirmation tone is heard. 'Ride Height: Normal' appears in the left-hand display and the vehicle lift icon extinguishes.

If there is no further activity, the left-hand display will exit after the timeout duration has been exceeded back to homescreen. To set the timeout to home screen duration, see Home screen, page 3.8.

INSTRUMENTS

LEFT-HAND DISPLAY

Time display



The clock appears in the top right-hand corner of the left-hand display

i *NOTE: The time can be displayed in a 12 hour or 24 hour format. The time and date are set manually, see Time and Date, page 3.8.*

Gearbox mode indicator



The gearbox mode indicator shows the current mode selected:

- Automatic **A**
- Manual **M**
- Temporary manual **A/M**
- Launch **L**

For more information, see Manual/Automatic mode, page 2.19.

INSTRUMENTS

LEFT-HAND DISPLAY

Messages - Coupe and Spider

The left-hand display may show messages that refer you to the Owner Manual. The table below indicates what you should do when one of these messages is displayed.

Message	Action
ESC OFF Invalid Operation See Owners Manual	The ESC deactivation procedure has not been followed correctly. See Electronic Stability Control, page 2.34.
Airbrake Restricted Low Vehicle Speed See Owners Manual	<ul style="list-style-type: none">• Raise the vehicle speed above 9 mph (15 kph) and press the AERO button.• or to lower the Airbrake while the vehicle is travelling below 9 mph (15 kph) or is stationary, press the AERO button for 5 seconds, the Airbrake will begin to lower. Hold the AERO button for a further 3 seconds until the Airbrake has lowered fully to the normal driving position
Clutch Over Temperature See Owners Manual	The vehicle has been subject to extreme operating conditions. This may be caused by excessive hill starts, repeated hard acceleration, driving slowly up steep hills for extended periods. As a result, the gearbox may limit engine torque. Stop the vehicle and allow the engine to idle in neutral for a few minutes.
Launch Mode Unavailable See Owners Manual	The conditions to enable a Launch have not been met, see Launch control, page 2.29.
Immobiliser Failure See Owners Manual	Contact your McLaren Retailer immediately.
Use Emergency - Start Receptacle See Owners Manual	The key fob is not functioning correctly. To start the engine, see Starting the vehicle, page 5.25.

INSTRUMENTS

LEFT-HAND DISPLAY

Message	Action
Low brake fluid level See Owners Manual	Top-up brake fluid, see Brake fluid, page 5.8.
Low steering fluid level See Owners Manual	Top-up the power steering fluid, see Power steering fluid, page 5.7.
Check pressure on front left tyre See Owners Manual	Inspect wheels and tyres, see Inspecting wheels and tyres, page 5.33.
Check pressure on front right tyre See Owners Manual	Inspect wheels and tyres, see Inspecting wheels and tyres, page 5.33.
Check pressure on rear left tyre See Owners Manual	Inspect wheels and tyres, see Inspecting wheels and tyres, page 5.33.
Check pressure on rear right tyre See Owners Manual	Inspect wheels and tyres, see Inspecting wheels and tyres, page 5.33.
Pressure low on front left tyre Stop vehicle	Stop the vehicle and inspect wheels and tyres, see Inspecting wheels and tyres, page 5.33.
Pressure low on front right tyre Stop vehicle	Stop the vehicle and inspect wheels and tyres, see Inspecting wheels and tyres, page 5.33.
Pressure low on rear left tyre Stop vehicle	Stop the vehicle and inspect wheels and tyres, see Inspecting wheels and tyres, page 5.33.

INSTRUMENTS

LEFT-HAND DISPLAY

Message	Action
Pressure low on rear right tyre Stop vehicle	Stop the vehicle and inspect wheels and tyres, see Inspecting wheels and tyres, page 5.33.
Airbrake system temporarily unavailable See Owners Manual	See Airbrake, page 2.36.
Winter mode unavailable See Owners Manual	See Winter mode, page 2.28.
Launch mode aborted See Owners Manual	See Launch control, page 2.29.
Battery low please charge See Owners Manual	See Charging the battery, page 5.13.
Key battery low See Owners Manual	See Replacing key fob battery, page 5.27.
Low windscreen washer fluid See Owners Manual	Top-up windscreen washer fluid, see Windscreen washers, page 5.9.
Passenger's seat obstructed move seat upwards See Owners Manual	See Electric seats*, page 1.29.

Message	Action
ESC Failure - Go to McLaren Service Centre	The Electronic Stability Control is not functioning correctly. As a result, the engine torque will be significantly limited and the vehicle will enter Limphome mode. Care should be taken while driving in this condition, the braking and traction control related driving aids will not be fully functional. Please contact your McLaren Retailer, see Electronic Stability Control, page 2.34.
Vehicle Limphome - Stop and restart the vehicle	The vehicle has recovered from a previous system error. As a result in this mode, the engine torque will be significantly limited. Care should be taken while driving in this condition. To reinstate full performance please stop the vehicle and restart the engine. If the problem persists, contact your McLaren Retailer. See Limphome mode, page 2.13.
Climate Control Fault - Go to McLaren Service Centre	The climate control system is not functioning correctly. Please contact your McLaren Retailer. See AIR CONDITIONING, page 4.4.
Catalyst Temperature	See Exhaust Temperature Monitoring, page 2.14 and Limphome mode, page 2.13.

INSTRUMENTS

LEFT-HAND DISPLAY

Messages - Spider Only

The left-hand display also shows messages relating to the roof and refer you to the Owner Manual. The table below indicates what these messages mean and what action you should take should you need to.

Message	Action
Roof Operation In Progress	Message is displayed during a roof open/close cycle. See Retractable Roof - Spider models, page 1.14.
Roof Open	Message is displayed when the roof has completed the stow (open) cycle. See Retractable Roof - Spider models, page 1.14.
Roof Closed	Message is displayed when the roof has completed the raise (close) cycle. See Retractable Roof - Spider models, page 1.14.
Continue Roof Cycle	Message is displayed when the roof has been stopped in an intermediate position during a open/close cycle. Operate the roof switch in the desired direction. See Retractable Roof - Spider models, page 1.14.
Reduce Vehicle Speed, Release and Re-press Button For Roof Operation	Message is displayed if the vehicle has exceeded 19 mph (30 kph) during a open/close cycle. Reduce the vehicle speed and operate the roof switch in the desired direction. See Retractable Roof - Spider models, page 1.14.
Roof Not Locked	Message is displayed if the roof has not been fully locked and the vehicle has exceeded 19 mph (30 kph). Reduce the vehicle speed and operate the roof switch in the desired direction. See Retractable Roof - Spider models, page 1.14.
Ambient Temp Too Low	Message is displayed if the ambient temperature is below -10°C (14°F). Roof operation will be inhibited until the ambient temperature has risen to allow safe operating level. See Roof Operating Temperature, page 1.14.

INSTRUMENTS

LEFT-HAND DISPLAY

Message	Action
Hydraulic System Over Temperature	Message is displayed if the roof hydraulic system has become too hot. Roof operation will be inhibited until the hydraulic system cools to allow safe operating level. Please contact your McLaren Retailer.
Bad Supply Voltage - Start Engine	Message is displayed if the vehicle battery charge has become too low. Start the engine and allow the battery to be charged. Operate the roof switch in the desired direction. Please contact your McLaren Retailer.
Roof System Power Down - Roof Not Secure	Message is displayed when the roof has been stopped in an intermediate position during a open/close cycle and the roof system has turned off. Operate the roof switch in the desired direction. Please contact your McLaren Retailer.
Tonneau Operation In Progress	Message is displayed during tonneau cover open/close cycle. See Tonneau Cover - Spider models, page 1.19.
Tonneau Open	Message is displayed when the tonneau has completed the open cycle. See Tonneau Cover - Spider models, page 1.19.
Tonneau Closed	Message is displayed when the tonneau has completed the close cycle. See Tonneau Cover - Spider models, page 1.19.
Roof Failure	Message is displayed if there is a operational malfunction. Roof operation will be inhibited. Please contact your McLaren Retailer.

INSTRUMENTS

LEFT-HAND DISPLAY

Message	Action
Confirm Tonneau Empty	Message is displayed if the tonneau cover has been opened at any time whilst the roof has been raised and the roof or backlight switches have been pressed down to the lower (open) position. By releasing the switch and pressing OK on the menu control stalk, you confirm the tonneau area is empty and you accept if this is not the case that damage may occur to the retractable roof or backlight during operation. The roof or backlight will begin to lower (open) once the respective switch is pressed. See Retractable Roof - Spider models, page 1.14 and Backlight - Spider models, page 1.17.
Engine Cover Open	Message is displayed if the engine cover has been opened and not closed correctly. Close the engine cover and operate the roof or tonneau switch in the desired direction. See Engine cover, page 1.11.
Open Doors To Complete Operation	Message is displayed if the roof control unit is unable to confirm door status. Roof operation will be inhibited until the door status can be confirmed. Please contact your McLaren Retailer.
Continue Tonneau Cycle	Message is displayed when the tonneau cover has been stopped in an intermediate position during a open/close cycle. Operate the tonneau switch in the desired direction. See Tonneau Cover - Spider models, page 1.19 and Retractable Roof - Spider models, page 1.14.

Gear position indicator



The gear position indicator (1) shows the current gear position selected; forward gear number, neutral or reverse.

When driving in manual mode, the gear position indicator will change from orange to red to indicate that an upshift is required to maintain optimum performance.

Display window



The display window (2) provides the driver with visual confirmation of cruise control speed and Electronic Stability Control status.

Handling and powertrain display



Confirmation of the handling and powertrain mode selected (3) is displayed. For more information on the different settings that are available, see Active dynamics control, page 2.23.

i NOTE: If the ACTIVE button has not been pressed (active dynamics panel is off), the Handling and Powertrain displays will both show Normal.

INSTRUMENTS

RIGHT-HAND DISPLAY

Additionally, if all conditions for a particular mode are not met when the selection is made, the mode will not be implemented until the conditions are met.

Oil temperature



The oil temperature is displayed in the form of a coloured bar graph (1) on the right-hand side of the instrument cluster.

When the engine is first started the bar will be BLUE. As the engine warms up the colour will change to GREY, indicating normal temperature.

High temperature is indicated if the bar turns ORANGE and excessive temperature is indicated by the bar turning RED.

If the gauge shows high temperature, ORANGE, slow down until the temperature drops to normal. If the temperature continues to rise and the bar turns RED, a warning message will appear in the left-hand display.

Stop the vehicle as soon as safety permits and contact your McLaren Retailer immediately.

INSTRUMENTS

RIGHT-HAND DISPLAY

Water temperature



The water temperature is displayed in the form of a coloured bar graph **(2)** on the right-hand side of the instrument cluster.

When the engine is first started the bar will be BLUE. As the engine warms up the colour will change to GREY, indicating normal temperature.

High temperature is indicated if the bar turns ORANGE and excessive temperature is indicated by the bar turning RED.

If the gauge shows high temperature, ORANGE, slow down until the temperature drops to normal. If the temperature continues to rise and the bar turns RED, a warning message will appear in the left-hand display.

Stop the vehicle as soon as safety permits and contact your McLaren Retailer.

Fuel level



The fuel level is displayed in the form of a coloured bar graph **(3)** on the right-hand side of the instrument cluster. The bar will usually be GREY. When the bar turns RED there is approximately 2.4 UK gallons (11 litres) of fuel remaining in the tank.



WINDOWS

Safety.....	4.2
Opening and closing.....	4.2

AIR CONDITIONING

Overview.....	4.4
Controls.....	4.4
AC button.....	4.5
Modes of operation.....	4.5
Temperature control.....	4.7
Blower speed control.....	4.8
Air distribution settings.....	4.9
Demisting/Defrosting.....	4.9
Air Recirculation mode.....	4.10
System Calibration.....	4.11
Heated rear screen.....	4.11

VEHICLE TRACKING*

Overview.....	4.12
Automatic Driver Recognition cards.....	4.12
Remote Keypad (Belgium only).....	4.13
In the event of a theft.....	4.13
Disabling the Tracker system.....	4.14
Vehicle Tracking Centre.....	4.14
False alarms.....	4.15
False alarm policy.....	4.15

INTERIOR FEATURES

Interior lighting.....	4.16
Entry lighting.....	4.16
Exit lighting.....	4.17
Stowage net.....	4.17
Sun visors.....	4.19
Stowage compartment.....	4.19
Cup holders.....	4.20
Owner documentation.....	4.20
Accessory power sockets.....	4.21
Car cover.....	4.22

Safety

WARNING: Ensure that no one can be trapped as you open or close the windows. Do not rest any part of your body against the window. There is a risk of becoming trapped by the movement of the window. If there is a risk of entrapment, stop movement of the window.

Opening and closing

WARNING: The key fob allows the engine to be started and is also used to activate other features on the vehicle.

Take the key fob with you, every time you leave the vehicle to prevent unsupervised operation of the windows, which may result in injury.

Switches for both windows are located on the driver's door console. A switch for the passenger's window is located on the passenger's door console.

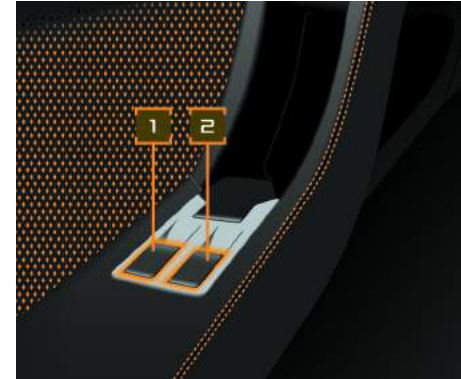

1. Driver's window switch.
2. Passenger's window switch.

Press switch **(1)** or **(2)**. The window will open for as long as the switch is pressed.

Pull switch **(1)** or **(2)**. The window will close for as long as the switch is pressed.

To open or close a window fully, press or pull switch **(1)** or **(2)** fully and release.

i *NOTE: To stop a window opening or closing, press or pull the appropriate switch.*

i *NOTE: If the vehicle ignition is in the accessory stage and the windows are not fully closed, window control is still available for a period of 60 seconds, or until the window becomes fully closed.*

Resetting the windows

The windows must be reset if the battery has been discharged or disconnected, or if the anti-trap feature has been activated.

Ensure that both doors are closed and the ignition is switched on.

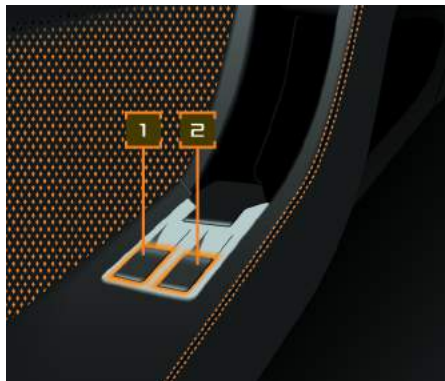

Push switches **(1)** and **(2)** downwards until the windows are open and hold them in this position for 5 seconds.

Pull both switches upwards until the windows are closed and hold them in this position for 5 seconds.

The windows are now reset.

If this does not resolve the issue, please contact your McLaren Retailer immediately.

Anti-trap protection

⚠ WARNING: Do not leave children unattended in the vehicle, they could be injured by the movement of the window.

Anti-trap protection will stop windows closing if an obstruction or resistance is detected.

If the anti-trap protection is triggered, check the window and the window aperture and remove any obstruction, before operating the windows again. In the event of an anti-trap event when closing the door, see Closing a door, page 1.10.

COMFORT AND CONVENIENCE

AIR CONDITIONING

Overview

The system can be operated in automatic mode or settings can be adjusted manually.

The combination filter reduces the quantity of dust and pollutants entering the car.

⚠ WARNING: Follow the recommended settings given for heating or cooling. If the windows mist up, you may no longer be able to observe road and traffic conditions and could cause an accident.

i *NOTE: The air conditioning system operates more effectively with the doors and windows closed. However, if the vehicle has been standing in a hot environment for a long time, ventilate by opening the windows briefly.*

i *NOTE: The interior air temperature sensor is located between the steering wheel and the centre console. Do not obstruct airflow to this sensor or the performance of the air conditioning system will be reduced.*

i *NOTE: The vehicle will retain the current air conditioning settings when the ignition is switched off.*

Controls



The air conditioning system is operated using controls located on the driver's and passenger's door consoles. When MONO is selected, the driver can adjust the blower speed, and the temperature on the passenger's side of the vehicle.

Driver's air conditioning controls

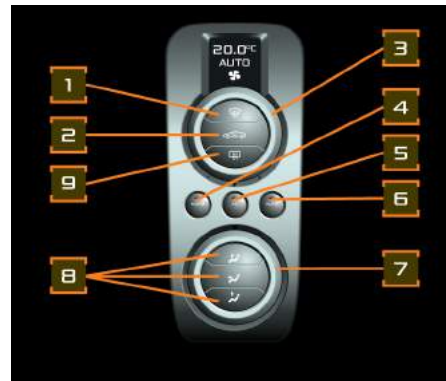

1. Windscreen demist button
2. Air recirculation button
3. Temperature control
4. MONO button
5. Air conditioning (AC) button
6. AUTO button
7. Blower speed control
8. Air distribution buttons
9. Heated rear window button

Passenger's air conditioning controls

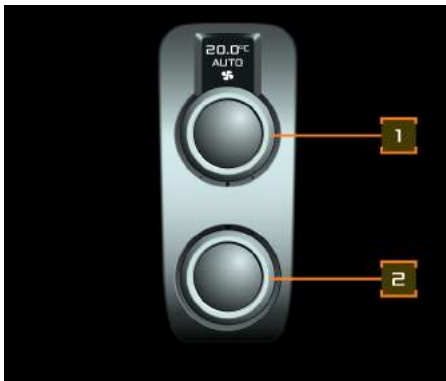

1. Temperature control
2. Blower speed control

AC button

 The air conditioning can be switched off at any time in any mode. Press the AC button. The light on the button extinguishes.

To switch the air conditioning on, press the AC button again, the light on the button illuminates.

Modes of operation

Automatic mode

 In automatic mode, the air conditioning system maintains the set interior temperature using a combination of differing blower speeds, air recirculation and air distribution.

To switch on automatic mode, press the AUTO button.

The light on the button illuminates and the air distribution, temperature and blower speed are adjusted automatically on both sides of the vehicle.

AUTO will appear on the display on driver's and passenger's door consoles.

In AUTO mode, there is no need to adjust the blower speed or air distribution, the system will operate whichever controls it needs to maintain the set temperature.

If you do wish to change the air distribution of the air conditioning system, press the preferred button. This will then put the system into AUTO fan mode.

COMFORT AND CONVENIENCE

AIR CONDITIONING

This is denoted by the fan symbol underneath AUTO in the display console. The system will still continue to control the blower speed to maintain the set temperature. There is an additional mode known as AUTO LO. The AUTO LO function operates the fan at lower speeds to achieve and maintain the desired cabin temperature. This reduces the level of sound emitted from the air conditioning system whilst retaining auto functionality.

To switch on AUTO LO, press the AUTO button once when in AUTO mode. The LED will remain lit and the text will change in the display to AUTO LO.

To return to AUTO, press the AUTO button a single time.

AUTO LO can be entered from manual mode with a double press of the AUTO button.

If necessary, the system settings can be manually adjusted, see Manual mode, page 4.6.

Manual mode

To adjust the air temperature manually, see Temperature control, page 4.7.

To adjust the blower speed manually, see Blower speed control, page 4.8.

When either the air temperature or blower speed is adjusted manually, the light on the AUTO button will extinguish and the blower speed will appear on the display on driver's and passenger's door consoles.

MONO mode button



MONO mode allows the driver to transfer their air temperature settings directly over to the passenger's air conditioning control panel

Press the MONO button, the light on the button will illuminate and all air temperature settings will be transferred over to the passenger's air conditioning control panel. Any changes the driver makes on their air conditioning control panel, will change automatically on the passenger's air conditioning control panel.

If the passenger then adjusts any of the air temperature settings on their air conditioning control panel, MONO mode will be deactivated. The MONO button light will then extinguish.

The driver can exit MONO mode at any time by a single press of the MONO button. The MONO button light will then extinguish.

COMFORT AND CONVENIENCE

AIR CONDITIONING

Temperature control



Rotate the control clockwise to increase the temperature, or anti-clockwise to decrease.

Press the **AUTO** button to return to automatic mode.

i *NOTE: The temperature can be adjusted in 0.5°C (0.5°F) increments from 16°C to 28°C (61°F to 82°F). Change the temperature in small increments, until the desired setting is achieved.*

To set the temperature to maximum, rotate the control clockwise until 'HI' is displayed. In **AUTO** mode, the air conditioning adjusts the air temperature to the highest setting, the blower speed is set to maximum and air is directed to the footwells.

To set the temperature to minimum, rotate the control anti-clockwise until 'LO' is displayed. In **AUTO** mode, the air conditioning sets the air temperature to the lowest setting, the blower speed is set to maximum and air is directed to the centre air vents.

The temperature set will appear on the displays on the driver's and passenger's door consoles.

i *NOTE: With 'LO' selected, it is not possible to switch off the air conditioning or switch on demist mode.*

COMFORT AND CONVENIENCE

AIR CONDITIONING

Blower speed control



Rotate the blower control clockwise to increase or anti-clockwise to decrease blower speed.

If in automatic mode, the light on the **AUTO** button will extinguish.

The blower speed will appear on the displays on the driver's and passenger's door consoles.

Press the **AUTO** button to return to automatic mode.

i *NOTE: When the engine is first started, the blower speed is limited and the air is directed at the windscreen until the engine has warmed up.*

Blower speed is also limited when the ignition is in the accessory position.

i *NOTE: When the engine is restarted from hot, the blower operates at low speed. This removes warm air from the vents, the blower speed will then increase to the requested setting.*

COMFORT AND CONVENIENCE

AIR CONDITIONING

Air distribution settings

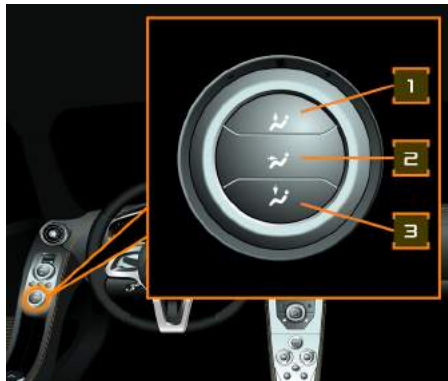

The air distribution can be set using the air-distribution controls.

Press button **(1)** to direct air to the windscreen, press button **(2)** to direct air to the centre air vents, press button **(3)** to direct air to the footwell vents.

All three buttons, a combination of any two or an individual button can be selected at any time.

When an air distribution button is pressed, the icon on the button will illuminate and the setting will be displayed briefly on the control panel.

Dashboard air vents



Turn a quarter turn in either direction until the vent is open or closed.

Demisting/Defrosting



Press the demist button. The icon on the button illuminates, the demist symbol appears in the control panel display and the air conditioning switches on if previously off. The blower will operate at full speed and the air temperature will be set to 'HI'.

i *NOTE: It is possible to manually reduce the blower speed using either the driver's or passenger's blower speed control, see Blower speed control, page 4.8.*

COMFORT AND CONVENIENCE

AIR CONDITIONING

i *NOTE: Air recirculation is inhibited when demist mode is selected.*

Press the demist button again to exit the demist mode. The icon on the button extinguishes, and the air temperature and blower speed return to their original settings.

Air Recirculation mode



Select Air recirculation when unpleasant smells or fumes are entering the vehicle.

⚠ WARNING: Switch to air recirculation mode briefly if outside temperatures are low. Be aware that the windows could mist up, which may impair your visibility. As a result, you could be distracted from road and traffic conditions and cause an accident.

i *NOTE: Switch on the air conditioning to prevent the windows misting.*

Press the air recirculation button, to select air recirculation. The icon on the button will illuminate. To switch off, press the air recirculation button again and the icon on the button will extinguish.

COMFORT AND CONVENIENCE

AIR CONDITIONING

System Calibration



The air conditioning system may periodically re-calibrate itself to ensure optimum system performance is maintained. During this cycle, the CAL symbol is shown on the display and system operation is inhibited.

Calibration should take no more than a minute and when complete, CAL will disappear from the display.

If CAL does not disappear, contact your McLaren Retailer.

Heated rear screen



⚠ WARNING: Remove any accumulated ice or snow from the windows before setting off. Impaired visibility could endanger yourself and others.

Press the button, to heat the rear screen. The icon on the button will illuminate. To switch off, press the button again and the icon on the button will extinguish.

i *NOTE: Switching on the heated rear screen also switches on the exterior mirror heaters.*

The rear screen heating switches off automatically after a set time, depending on the outside air temperature.

COMFORT AND CONVENIENCE

VEHICLE TRACKING*

Overview

This section provides an overview of the Vehicle Tracking service. If you need further clarification, contact Vehicle Tracking Customer Service.

The tracking system is a subscription based service which tracks vehicle movements in the event of a theft, sabotage attempts, vehicle break-in or GPS antenna tampering.

Depending on market specification, you have been supplied with two unique Automatic Driver Recognition cards, or two Vehicle Tracking Remote keys.

i *NOTE: Each driver must carry an Automatic Driver Recognition card whenever they drive the vehicle. If a keypad has been supplied, this must be used to enter a code every time the car is to be driven.*

Automatic Driver Recognition cards

When the ignition is switched off, the Vehicle Tracking system will automatically arm itself. If the vehicle is then moved (lifted, towed or driven) without the Automatic Driver Recognition card present, a silent alert is immediately sent to the Vehicle Tracking Centre.

i *NOTE: Store your Automatic Driver Recognition card away from keys when the vehicle is not in use to reduce the risk of the card being taken in the event of key theft.*

Do not leave your Automatic Driver Recognition card or certificate of tracker installation in the vehicle.



COMFORT AND CONVENIENCE

VEHICLE TRACKING*

Remote Keypad (Belgium only)

Your keypad is used to enter and transmit a code to the McLaren Tracking Service, in order to activate your Tracker System.

Once you have received the code, sent to your mobile phone, follow the procedure described.

You will need to enter this code every time that you use your vehicle.

If you wish to add or remove a keypad, contact your McLaren Retailer.

i *NOTE: Store your remote keypad away from keys when the vehicle is not in use to reduce the risk of the keypad being taken in the event of key theft.*

Do not leave your remote keypad or certificate of tracker installation in the vehicle.

Entering a code



1. Press the centre button, the LED will start flashing.
2. Enter the code supplied to your mobile phone, and press the centre button again.
3. The LED will stop flashing once the code is validated.
4. The tracker is now disarmed.

i *NOTE: You will need to enter this code every time that you use your vehicle.*

In the event of a theft

1. If you discover the vehicle has been stolen, call the Vehicle Tracking Centre in your home country,
or
if your vehicle is supplied with an Automatic Driver Recognition card and the vehicle is moved without this, the Vehicle Tracking Centre will initially send a text message to you to verify the vehicle movement. In addition to this, the Vehicle Tracking Centre will attempt to contact you using your mobile phone number then your home or office number provided you supplied them at the time of vehicle collection.
2. The Vehicle Tracking Centre will not contact the Police until they have spoken to you. Once you have confirmed the theft, they will commence the vehicle recovery procedure.
3. The Vehicle Tracking Centre will ask you to contact the Police to report the theft and call back with a Police incident number. Receipt of an alert does not

COMFORT AND CONVENIENCE

VEHICLE TRACKING*

constitute a confirmed theft, as the Police require your, or keyholder, verification of a theft.

If you are abroad at the time of theft, the Vehicle Tracking Centre will contact the Police in your home country for you to obtain a Police incident number.

4. The Vehicle Tracking Centre will then liaise with the relevant local Police to recover your vehicle.

In order to prevent your vehicle being moved following a theft, the Vehicle Tracking service may, under instruction from the Police, temporarily prevent the vehicle's engine from restarting (market dependant).

5. When the Police secure the stolen vehicle, arrangements will have to be made with you for the vehicle to be collected. The Police may recover the vehicle to a secure compound for further investigation.

You may be liable for any recovery and storage charges.

Disabling the Tracker system

There will be instances when you wish to disable your Tracker for specific periods of time.

These will include visits to your McLaren Retailer or if the car is to be transported on a trailer, train or ferry.

You can contact the Vehicle Tracking Centre and advise them that you wish the system to be placed in either 'Transport' or 'Garage' mode.

The operator will request the exact time that this should be implemented and also the duration. This will ensure that the system is only disabled for the minimum time necessary.

Vehicle Tracking Centre

If your car is stolen, contact the appropriate number from the table.

Country	Telephone
UK	+44 844 239 0035
Germany	+49 700 767 724 3887
Italy	+39 331 162 0856
Spain	+34 902 111 173
France	+33 892 701 440
Switzerland	+41 227 102 879
Belgium	+32 27 523 907
Netherlands	+31 882 020 927

The Vehicle Tracking Centres are operational 24 hours every day throughout the year (bank holidays included).



NOTE: The cost of calls is calculated according to the national tariff.

COMFORT AND CONVENIENCE

VEHICLE TRACKING*

Customer Service

If at any time you need to change any details you have entered in the McLaren Vehicle Tracking System Agreement or if you sell your vehicle, you MUST contact the Service Provider.

For example, if:

- You have changed your telephone/mobile phone number
- You have changed the registration plate on your vehicle
- You are moving house
- You are selling your vehicle
- You wish to add or remove an authorised driver

The Customer service operators can be contacted on:-

0844 239 0032 in the UK or from outside the UK on +44 (0)161 924 5404. Calls can be made between 09:00am – 17:00pm (GMT) Monday to Friday.

False alarms

To maintain the Vehicle Tracking service stolen vehicle recovery rates, customer support is needed to keep false alarms to a minimum.

 **NOTE:** *Ensure that the vehicle battery remains fully charged at all times, a discharged battery may lead to a false alarm.*

A disconnected battery may also lead to a false alarm.

False alarm policy

Following an alert, the Vehicle Tracking Centre will contact you to confirm the status of the vehicle. If the alert is a false alarm, this will be recorded on your account, you may be charged for excessive false alarms.

All Automatic Driver Recognition card users will be allowed up to 5 false alerts in a 12 month period.

 **NOTE:** *To avoid unnecessary alerts, contact the Vehicle Tracking Centre to inform them of any potential false alarms.*

Interior lighting



1. Left-hand reading light on/off/gradual touch pad
2. Right-hand reading light on/off/gradual touch pad
3. Interior lighting on/off touch pad

For full interior lighting, press the touch pad **(3)** quickly.

i *NOTE: Ensure that the interior lighting is switched off when leaving the vehicle.*

To switch off the interior lighting, press touch pad **(3)** again.

Reading lights

Press touch pads **(1)** or **(2)** to switch on the desired reading light.

For gradual reading illumination, press and hold touch pad **(1)** or **(2)** until desired lighting is achieved.

Press touch pads **(1)** or **(2)** again to switch off the respective reading light.

Courtesy lighting

The interior of your McLaren is lit in the following areas:

- the driver's and passenger's footwells, when you open a door
- the centre console (illuminated by a light within the overhead light panel), if the ignition is on
- the interior door handles, if the ignition is on

The courtesy lighting extinguishes one minute after the doors have been closed or when the ignition is switched on.

The luggage compartment light illuminates when the luggage compartment is opened.

Entry lighting

Entry lighting improves visibility and security when you approach the vehicle.

When the vehicle is unlocked, the headlamps and tail lamps illuminate for a period of time or until the ignition is switched on.

To set the entry lighting duration, see External lighting, page 3.9.

COMFORT AND CONVENIENCE

INTERIOR FEATURES

Exit lighting

Exit lighting improves visibility and security when you leave the vehicle by illuminating the headlamps and tail lamps for a period of time.

To set the exit lighting duration, see External lighting, page 3.9.

Exit lighting can also be activated manually by pulling the directional indicator stalk towards you momentarily three times. The vehicle must be in an awake state with the ignition off.

Every additional pull on the directional indicator stalk whilst the exit lighting has been activated will increase the time increment by an additional 15 seconds.

Once the vehicle has been exited, locked and completed its set operating time, the exit lighting will extinguish and the function will not be available, unless it is switched on in the instrument cluster or is manually activated again through the directional indicator stalk.

Stowage net

Bulkhead stowage net

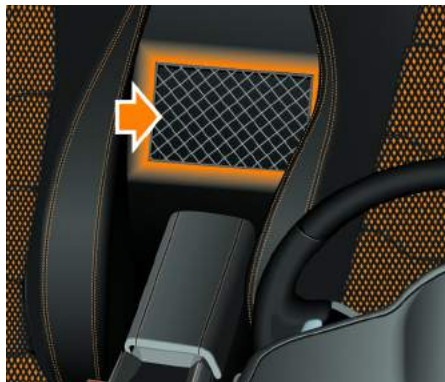

A stowage net is fitted on the bulkhead between the seats for storing small items.

i *NOTE: The maximum weight the stowage pocket can support is 1 kg (2.2 lbs).*

⚠ WARNING: Do not use the stowage net to transport any heavy, sharp-edged or breakable objects. Occupants could be injured by objects being thrown around during sharp braking, a sudden change of direction or an accident.

Passenger's footwell stowage net



There is a stowage net in the passenger's footwell for storing small items.

COMFORT AND CONVENIENCE

INTERIOR FEATURES

i NOTE: Maximum item sizes for the passenger's stowage net are as follows:

- Maximum item size 1 - 250 mm Height x 200 mm Width x 20 mm Depth.
- Maximum item size 2 - 100 mm Height x 200 mm Width x Depth 70 mm.

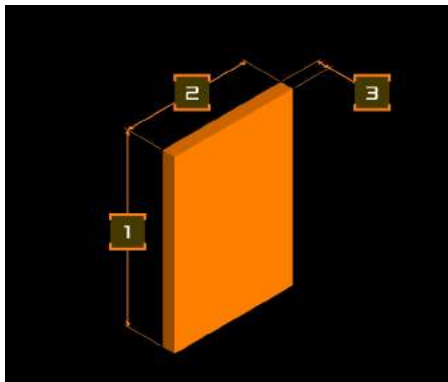

Passenger's footwell stowage net maximum item size 1 - 250 mm Height (1) x 200 mm Width (2) x 20 mm Depth (3).

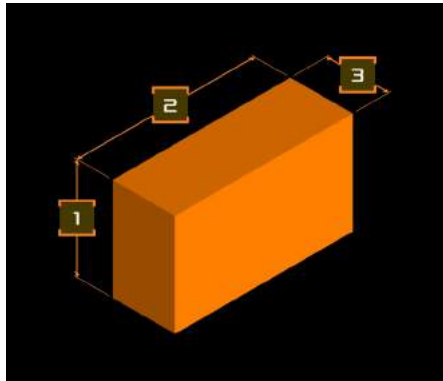

Passenger's footwell stowage net maximum item size 2 - 100 mm Height (1) x 200 mm Width (2) x Depth 70 mm (3).

! WARNING: Do not place items in the passenger's footwell stowage net that exceed the dimensions stated previously. It could lead to personal injury or prevent the occupant restraint system from performing correctly.

! WARNING: Do not use the stowage net to transport any heavy, sharp-edged or breakable objects. Occupants could be injured by objects being thrown around during sharp braking, a sudden change of direction or an accident.

COMFORT AND CONVENIENCE

INTERIOR FEATURES

Sun visors



Fold the sun visors down to protect your eyes from bright sunlight as you are driving.

Stowage compartment

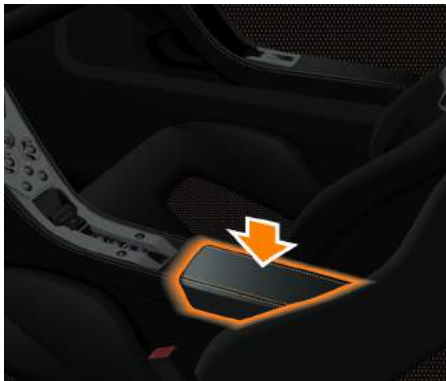



A compartment is fitted in the centre console for storing small items.

 **WARNING:** The stowage compartment must be closed when items are stored in it. Occupants could be injured by objects being thrown around during sharp braking, a sudden change of direction or an accident.



The USB connector and a 3.5 mm auxiliary audio input socket are located in the stowage compartment.

-  **NOTE:** Always close the stowage compartment when leaving the vehicle, or the interior motion sensor (if fitted) will not function.
-  **NOTE:** The area behind the seats is not designed for storing luggage or any other personal items.

COMFORT AND CONVENIENCE

INTERIOR FEATURES

Stowage pocket

A pocket is fitted to the front edge of each seat for storing small items.

Cup holders



Utilise the two cup holders for safe convenient storage of closed drink containers when on a journey.



WARNING: Drinking while the car is moving could cause you to become distracted which could lead to an accident.

Owner documentation

Your McLaren is equipped with the following documents:

- Quick guide - which gives a brief overview of the controls and instruments fitted to your McLaren.
- Service and Warranty booklet - provides information on what to do and who to contact in the event of problems.
- IRIS user guide - provides information on how to operate all the functions of the IRIS system fitted to your McLaren.

Accessory power sockets



These documents are stored in a slot under the dashboard on the passenger's side.



Luggage compartment socket

- i** The accessory socket, located in the luggage compartment, is the only one that can be used to connect the battery charger.
- i** **NOTE:** Do not leave any device (except the battery charger), that draws power from the vehicle, connected to the socket for extended periods without the engine running. This may lead to excessive battery drain.



Interior accessory 12V socket

- The interior accessory 12V socket is located inside the passenger compartment, behind the centre console.
- i** **NOTE:** Do not connect the battery charger to the interior accessory socket.

Car cover

A car cover, suitable for use inside a garage, can be purchased from your McLaren Retailer.

McLaren recommends that the car is covered if it is to be left in storage for periods over two weeks. Clean the vehicle inside and out, ensuring that it has fully dried, prior to fitting the cover.

 *NOTE: Allow the engine to cool before fitting the cover or the hot exhaust pipes could cause damage to the cover.*



FLUID TOPPING UP

Engine oil.....	5.2
Gearbox oil level	5.5
Coolant.....	5.6
Power steering fluid.....	5.7
Brake fluid	5.8
Windscreen washers.....	5.9

EMERGENCY EQUIPMENT

Emergency Equipment Safety	5.10
Luggage compartment equipment	5.10
Warning triangle*.....	5.10
First Aid kit*	5.11
Tyre sealant.....	5.11
Towing eye	5.12
Fuel funnel.....	5.12
Fire extinguisher*.....	5.12

BATTERY CARE AND MAINTENANCE

Battery safety	5.13
Charging the battery	5.13
Boost starting from another vehicle.....	5.14

FUSES

Fuse replacement.....	5.17
Main fuse box.....	5.17
Secondary fuse box.....	5.20
Battery fuse box.....	5.21

LIGHTING

Vehicle lights	5.23
----------------------	------

MANUAL UNLOCKING AND OPENING

Unlocking - discharged battery	5.24
Starting the vehicle.....	5.25
Door opening from inside - discharged battery.....	5.26
Opening luggage compartment - discharged battery.....	5.27
Replacing key fob battery	5.27

WASHERS AND WIPER

Replacing the wiper blade.....	5.30
--------------------------------	------

WHEELS AND TYRES

Wheels and tyres.....	5.31
Deflated tyre.....	5.35
Trofeo R tyres*.....	5.36

VEHICLE CARE

Washing your McLaren.....	5.38
Cleaning the interior	5.40

RAISING THE VEHICLE

Vehicle lifting points.....	5.42
-----------------------------	------

McLAREN ASSISTANCE

McLaren Assistance.....	5.43
Replacement battery	5.43
In the event of a breakdown	5.43
Towing for recovery.....	5.44

DRIVING ABROAD

Driving abroad.....	5.45
---------------------	------

Engine oil



The engine uses approximately 0.1 litres of oil for every 625 miles (1,000 km), depending on your style of driving. The oil consumption may be higher than this when the vehicle is new or if you frequently drive at high engine speeds.

You will only be able to estimate the oil consumption after the vehicle has been driven for several thousand miles or kilometres.

i *NOTE: Lubricant additives could damage the engine or gearbox. Damage caused by such additives is not covered by the vehicle warranty. Further information is available from your McLaren Retailer.*

Checking the engine oil

The engine oil level must be manually checked. No automatic level checks or warnings are provided.

To check the engine oil level manually:

1. Ensure the following conditions are met:
 - Vehicle stationary and positioned on a level surface.
 - Neutral selected and the foot brake applied (use left foot).

i *NOTE: The foot brake must be applied for the entire duration of the oil level check.*

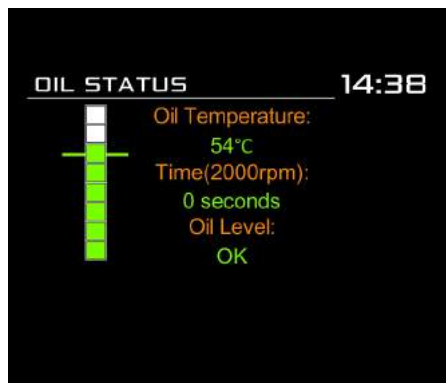

2. The level is viewed in the Vehicle Info section in the left-hand display, see Vehicle info, page 3.17.
3. Start the engine and hold the engine speed at 2,000 rpm for 40 seconds. Allow the engine oil temperature to reach a temperature between 40°C (104°F) and 70°C (158°F).

i *NOTE: The throttle can be fully depressed as the engine speed will be electronically limited to 2,000 rpm.*

4. When the timer has reached '0', the oil level will be shown on the display along with a description.

i *NOTE: The line on the display indicates the maximum oil level for 19 seconds after the oil level is read.*

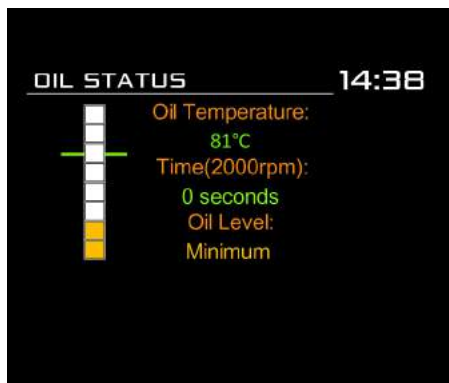

5. If the engine oil is below the target level, top up the oil in accordance to the following procedure.

i *NOTE: Once the oil level check has been completed and returned a value, do not continue to test the system. This may lead to aeration of the oil and return a false value. To end the oil level check, release the throttle pedal and return to the Vehicle info menu by moving the menu stalk back.*

Topping-up the engine oil

! **WARNING:** There is a risk of injury if the engine cover is open, even when the engine is not running.

Engine components become very hot. Avoid contact, there is a risk of severe burns.

- i** *NOTE: The engine must be switched off before carrying out the oil top up process.*
- i** *NOTE: McLaren only recommends the use of Mobil 1 New Life 0W-40 engine oil.*

1. Open the engine cover, see Engine cover, page 1.11.



2. Unscrew the engine oil filler cap.
3. Top-up with the correct quantity of Mobil 1 New Life 0W-40 engine oil, in 0.25 litre quantities. Approximately 2.75 litres is required to raise the level from minimum to maximum. Refer to Top-up quantity, page 5.5.

i *NOTE: Do not overfill. Top-up in 0.25 litre quantities and then re-check before adding further oil.*

MAINTAINING YOUR McLAREN

FLUID TOPPING UP

4. Check the left-hand display to ensure level is correct.

i *NOTE: If you have inadvertently overfilled the engine with oil, you must have any excess removed at your McLaren Retailer. The engine or the catalytic converter could be damaged.*

5. Refit the engine oil filler cap.

🌱 ENVIRONMENTAL: When topping up, take care not to spill any oil. Oil must not be allowed to escape into the soil or waterways.

i *NOTE: Ensure oil filler cap is refitted correctly, with the markings on the cap and bowl aligned. If not, it may become detached and allow oil to escape the system. If closed correctly the handle should be facing directly to the front of the car with the recesses parallel to the engine compartment side covers.*



6. Close the engine cover, see Engine cover, page 1.11.

MAINTAINING YOUR McLAREN

FLUID TOPPING UP

Top-up quantity

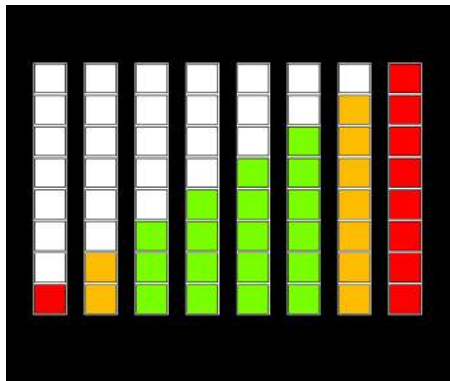

Based on the oil status displayed on the left-hand display, add the required quantity of oil as shown in the following table.

Bars on display	Quantity of oil required
1 bar - red - under filled	1.00 litre
2 bars - yellow - min.	0.75 litre
3 bars - green - OK	0.50 litre
4 bars - green - OK	0.25 litre
5 bars - green - OK	0.10 litre
6 bars - green - target	0 litre
7 bars - yellow - max.	0 litre
8 bars - red - overfilled	Contact your McLaren Retailer

Oil temperature

If the oil temperature is too high, a warning will be displayed in the left-hand display. Reduce the vehicle and engine speed until the warning message disappears.

Gearbox oil level

If you experience oil loss or problems with gear shifts, have the gearbox checked by your McLaren Retailer.

i *NOTE: The clutch and gearbox oil has mileage related service intervals. This maintenance can only be carried out by your McLaren Retailer.*

Coolant

Coolant is a mixture of water and antifreeze/corrosion inhibitor. Only check the coolant when the vehicle is positioned on level ground and the engine is cool.

Topping-up the coolant

WARNING: The cooling system is pressurised. Only unscrew the cap when the engine is cool. You could be scalded by hot escaping coolant if you attempt to unscrew the cap whilst the engine is still warm.

WARNING: Coolant is highly flammable. Fire, naked flames and smoking are prohibited when handling coolant.

WARNING: Coolant is toxic. Keep containers sealed and away from children. If coolant is accidentally consumed, seek medical help straight away.

NOTE: The engine must be switched off before carrying out the coolant level check and top up process.

1. Open the engine cover, see Engine cover, page 1.11.

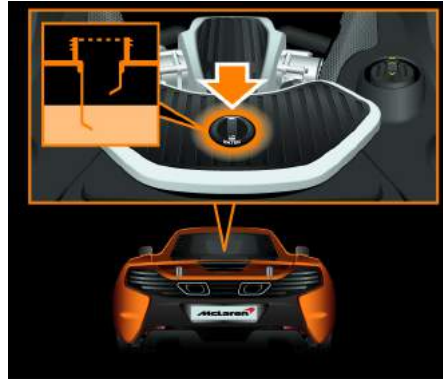



2. Slowly unscrew the cap by half a turn anti-clockwise and allow excess pressure to escape.
3. Unscrew the cap fully and remove it.
4. The coolant level is correct when it is between the lower and upper steps inside the filler neck.
5. Top-up if necessary using only Mobil Antifreeze Extra.

6. Replace the cap by turning it clockwise to the stop.

7. Close the engine cover, see Engine cover, page 1.11.

Power steering fluid

 **WARNING:** Power steering fluid is highly flammable. Fire, naked flames and smoking are prohibited when handling power steering fluid.

 **WARNING:** Power steering fluid is toxic. Keep containers sealed and away from children. If fluid is accidentally consumed, seek medical help straight away.

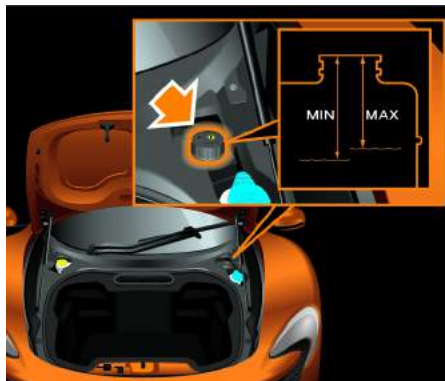

Right-hand drive models

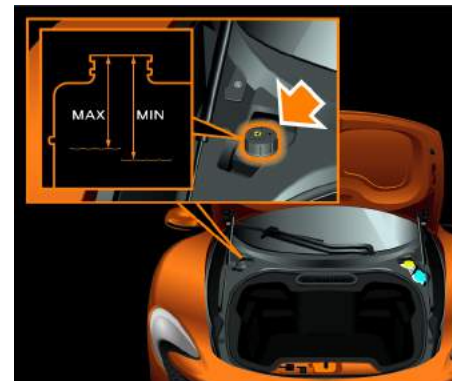

Left-hand drive models

Checking fluid level

1. Switch the ignition on and start the engine. Select normal handling mode, see Handling control, page 2.24.
2. Allow the engine to idle for 20 seconds before checking the fluid level.
3. Open the luggage compartment, see Luggage compartment, page 1.12.
4. Turn the cap anti-clockwise and remove it.
5. Measure the distance, inside the reservoir, down to the fluid level. Maximum fill level is 50 mm and minimum fill level is 55 mm from the top of the filler neck.
6. Top up if necessary using only Pentosin CHF202 power steering fluid, contact your McLaren Retailer.
7. Replace the cap by turning it to the stop.
8. Close the luggage compartment, see Luggage compartment, page 1.12.

MAINTAINING YOUR McLAREN

FLUID TOPPING UP

Brake fluid

⚠ WARNING: Brake fluid is highly flammable. Fire, naked flames and smoking are prohibited when handling brake fluid.

⚠ WARNING: Brake fluid is toxic. Keep containers sealed and away from children. If fluid is accidentally consumed, seek medical help straight away.

⚠ WARNING: Only use fluid from new, air tight containers.

i NOTE: Avoid spilling brake fluid, it is harmful to painted surfaces. Any spillages must be removed immediately with a mixture of car shampoo and water.

i NOTE: The engine must be switched off before carrying out the brake fluid check and top up process.

Checking fluid level

1. Open the luggage compartment, see Luggage compartment, page 1.12.



Right-hand drive models

2. Unscrew the cap anti-clockwise and remove it.

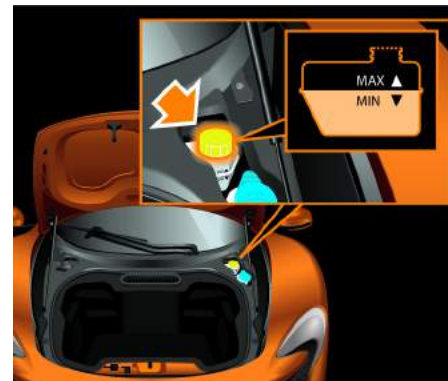

Left-hand drive models

3. The brake fluid is correct if the level just covers the base of the filter in the filler neck.
4. Top up if necessary using only new Pentosin DoT 5.1 brake fluid.
5. Replace the cap by turning it to the stop.
6. Close the luggage compartment, see Luggage compartment, page 1.12.

Windscreen washers

 **WARNING: Some washer fluids are highly flammable. Fire, naked flames and smoking are prohibited when handling washer fluid.**

 **WARNING: Washer fluid is toxic. Keep containers sealed and away from children. If fluid is accidentally consumed, seek medical help straight away.**

 **NOTE: McLaren recommends the use of Mobil Screenwash concentrate.**

 **NOTE: Add washer fluid to the reservoir all year round.**

The reservoir for the windscreen washers is located in the luggage compartment.

The reservoir has a capacity of approximately 4 litres.

Checking fluid level

1. Open the luggage compartment, see Luggage compartment, page 1.12.
2. Mix a solution of Mobil Screenwash concentrate and water in a container before adding to the reservoir. Concentration of the washer solution should be mixed to suit the outside temperatures.



3. Open the reservoir cap, top up the reservoir with washer fluid and close the cap.

4. Close the luggage compartment, see Luggage compartment, page 1.12.

Emergency Equipment Safety

Before using the emergency equipment, familiarise yourself with the following safety information.

WARNING: Always ensure the emergency equipment supplied is used in the proper manner and for the purpose it was designed. Always use the emergency equipment in a safe and responsible manner and be aware of other road users.

Luggage compartment equipment

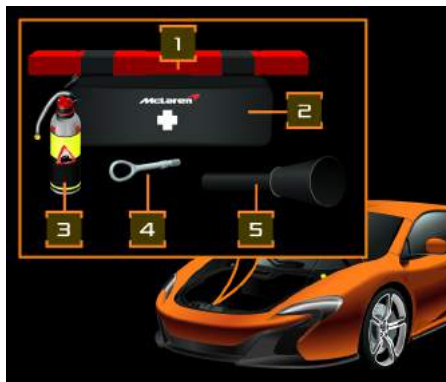

1. Warning triangle*, page 5.10
2. First Aid kit*, page 5.11
3. Tyre sealant, page 5.11
4. Towing eye, page 5.12
5. Fuel funnel, page 5.12

i NOTE: The towing eye and the fuel funnel are supplied fitted inside the first aid kit container.

Warning triangle*



The warning triangle (1) is located at the front of the luggage compartment.

Setting up the warning triangle

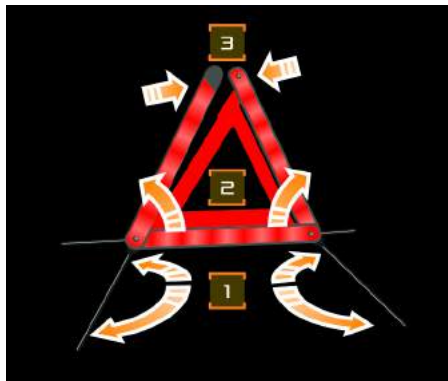

Fold the legs (1) sideways from the bottom.

Pull side reflectors (2) upwards to form a triangle and lock them at the top using press-stud (3).

Place the warning triangle at an appropriate distance from the vehicle to warn other traffic of a breakdown.

First Aid kit*



The first aid kit (2) is located at the front of the luggage compartment.

i *NOTE: Check the expiry dates of the first aid kit materials every year, and replace them if necessary.*

Tyre sealant



The tyre sealant (3) is located at the front of the luggage compartment luggage.

For instructions on how to use the tyre sealant, see Deflated tyre, page 5.35.

i *NOTE: Check the expiry date of the tyre sealant every year, and replace if necessary.*

MAINTAINING YOUR McLAREN

EMERGENCY EQUIPMENT

Towing eye



The towing eye (4) is located inside the first aid kit case at the front of the luggage compartment luggage.

i *NOTE: Your McLaren is equipped with a front towing eye mounting only. It is not possible to tow other vehicles.*

For information on installing the towing eye, see Towing eye and mounting, page 5.44.

Fuel funnel



The fuel funnel (5) is located inside the first aid kit at the front of the luggage compartment luggage.

i *NOTE: Only use the fuel funnel when filling the vehicle with fuel from sources other than a fuel pump on a garage forecourt.*

Do not use the fuel funnel when topping-up coolant, engine oil or any other fluids in the vehicle.

Fire extinguisher*

The fire extinguisher is located at the front of the luggage compartment.



Release the retaining strap and remove the fire extinguisher.

To operate, follow the manufacturer's instructions on the side of the fire extinguisher.

i *NOTE: The fire extinguisher must be checked every year or it may fail in an emergency. Once the extinguisher is used it will have to be replaced.*

Battery safety

i **NOTE:** Your McLaren is fitted with a lithium ion battery. Only a lithium ion battery charger can be used on this type of battery. Contact your McLaren Retailer for more information.

Before using the battery charger, familiarise yourself with the following safety information.

! **WARNING:** The lithium ion battery fitted to your McLaren is sealed for life and no attempt should be made to break the battery seal to inspect the battery cells.

! **WARNING:** Have the battery tested at your McLaren Retailer, every two years or 12,000 miles (20,000 km) and replaced if necessary. Your McLaren Retailer will inform you if it is necessary to replace the 12V battery.

! **WARNING:** Leave a suitable lithium ion battery charger connected to the lithium ion battery and switched on during periods when your vehicle is not in regular use. This will help maintain and prolong the life of the battery.

! **WARNING:** Before use, check that all cables are in good condition; do not use cables that are damaged.

Ensure that all cables are kept away from sharp edges, are not pinched or trapped and are not close to hot surfaces or water.

Never charge a damaged battery. The battery must only be charged in a well ventilated area; the charger must never be covered or placed on the battery.

Do not place any metal objects on a battery. You could cause a short circuit and the battery could ignite.

Keep the charger out of reach of children at all times.

Charging the battery

i **NOTE:** To maintain your lithium ion battery in optimum condition, always leave the battery charger connected to the battery and switched on during periods when your vehicle is not in regular use.

i **NOTE:** Do not connect the battery charger to the interior accessory socket.



Refer to the instructions supplied with the battery charger. The charger connects to the accessory socket in the luggage compartment.

MAINTAINING YOUR McLAREN

BATTERY CARE AND MAINTENANCE

Boost starting from another vehicle

Using booster cables

⚠ WARNING: Ensure that both batteries are 12V and that the booster cables have insulated clamps and are approved for use with 12V batteries.

⚠ WARNING: Do not connect positive (+) terminals to negative (-) terminals.

⚠ WARNING: Take care when working near rotating parts of the engine. Ensure cables are kept well clear.

i NOTE: Do not use a 24V booster start system. These produce excessive voltage and can damage the vehicle's electrical system.

i NOTE: It is not possible to push or tow start a vehicle with a discharged battery.

i NOTE: If using a donor vehicle, please allow it to have the engine running for a minimum of two minutes before trying to start the disabled vehicle.

Boosting procedure

1. If a donor vehicle is to be used, park it so that the battery location is adjacent, but ensure the two vehicles do not touch.
2. Apply the parking brake and ensure that the transmission of both vehicles is set in neutral (or Park for vehicles with automatic transmission).
3. Switch off the ignition and all electrical equipment in both vehicles.

i NOTE: Before connecting booster cables ensure that the battery connections on the disabled vehicle are correct and that all electrical equipment has been switched off.

4. Open the luggage compartment and remove any items stowed inside.

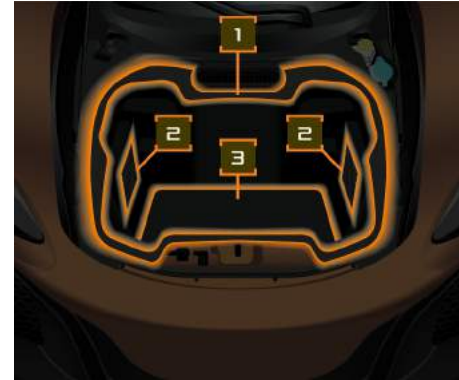

5. Remove the finisher **(1)** from around the top of the luggage compartment liner.
6. Remove the two stowage nets **(2)**.
7. Remove the carpet **(3)**.

MAINTAINING YOUR McLAREN

BATTERY CARE AND MAINTENANCE



8. Remove the 7 screws (4) securing the side and the base luggage compartment liner.
9. Remove the 10 screws (5) securing the top edge of the luggage compartment liner.
10. Remove the luggage compartment liner.

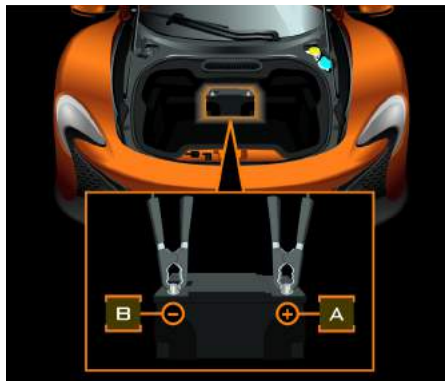

11. Connect one end of the positive (+) booster cable to the positive (+) terminal on the donor vehicle's battery.
12. Connect the other end of the positive (+) booster cable to the positive (+) terminal on the disabled vehicle's battery (A).
13. Connect one end of negative (-) booster cable to the negative (-) terminal on the donor vehicle's battery.
14. Connect the other end of the negative (-) booster cable to the negative (-) terminal on the disabled vehicle's battery (B).

15. Check that the cables are clear of any moving components and that all four connections are secure.

 **WARNING:** Ensure that each connection is securely made and that there is no risk of the clips accidentally slipping or being pulled from the connection points/battery terminal - this could cause sparking, which could lead to fire or explosion.

16. Start the engine of the donor vehicle and allow it to run for two minutes.
17. The electrical system on the disabled vehicle should now be ready for the engine to be started.
18. Start the engine of the disabled vehicle.
19. Allow both vehicles to idle for two minutes.
20. Switch off the donor vehicle.

 **NOTE:** Do not switch on any electrical circuits on the previously disabled vehicle until after the booster cables have been removed.



*NOTE: If battery is fully discharged, or has been disconnected, it may be necessary to reset the windows, see *Resetting the windows, page 4.3*. If this does not resolve the issue, please contact your McLaren Retailer immediately.*

Disconnecting the cables



WARNING: To avoid serious injury, use caution when removing the booster cables as the engine on the previously disabled vehicle will be running. You will be working close to components carrying high voltage, or may be hot.

1. Disconnect the booster cables in the reverse order to that used for connection.
2. Refit the luggage compartment liner and secure with the 17 screws.
3. Fit the stowage nets, the carpet and the top finisher.
4. Stow the contents removed from the luggage compartment.

Fuse replacement

WARNING: Fuses protect the vehicle's electrical systems. The failure of any fuse will render the system it protects inoperative.

Use replacement fuses of the same rating and type. Incorrect fuse ratings can overload a system and cause a fire or malfunction. Blown fuses should be replaced and no attempt should be made to repair a blown fuse.

i *NOTE: Before removing a fuse, turn off all electrical equipment and switch off the ignition.*

There are three fuse boxes fitted to your McLaren.

Fuse Box	Location
Main fuse box	Behind a panel in the rear bulkhead, behind the left-hand seat.
Secondary fuse box	Below the dashboard on the passenger's side.
Battery fuse box	On top of the Battery, in the luggage compartment, beneath the luggage compartment cover.

Main fuse box

Main fuse box access



1. To access the main fuse box:
 - pull the release strap and tilt the left-hand seat backrest forwards
 - if a racing seat is fitted, slide the racing seat forwards



2. Release the two lower clips securing the panel to the bulkhead and remove the panel
3. Refer to the fuse specification chart on page 18 to determine which fuse protects the non-functioning electrical system.

i *NOTE: A label identifying the fuses is attached to the inside of the access panel.*

4. Remove the appropriate fuse and replace it with a fuse of the same value as the original. If in doubt, check the fuse specification chart.
5. Fit the access panel by inserting the two upper retaining clips in the bulkhead and securing with the two lower clips.

i *NOTE: If a replacement fuse does not solve the electrical problem, or it fails immediately, contact your McLaren Retailer.*

Main fuse box fuse specification chart

No.	Amps	Circuit protected
F1	60	Secondary Air Pump
F2	-	-
F3	-	-
F4	-	-
F5	30	Powertrain Chassis Control Unit
F6	30	Powertrain Chassis Control Unit
F7	30	Starter
F8	20	Heated Rear Window
F9	30	Audio Amplifier
F10	40	Spider Roof Pump
F11	40	Spider Roof ECU
F12	-	-
F13	5	Powertrain Chassis Control Unit

MAINTAINING YOUR McLAREN

FUSES

No.	Amps	Circuit protected
F14	5	Engine Control Module
F15	10	Relays
F16	-	-
F17	3	Door Locking Switch
F18	50	ECU Main Relay Control
F19	30	Fuel Pump 2
F20	30	Seat Driver's
F21	30	Seat Passenger's
F22	30	Fuel Pump 1
F23	5	Tilt and Microwave Sensor
F24	-	-
F25	10	Driver's/Passenger's Door Latch
F26	10	ICPC
F27	5	Electronic Park Brake
F28	-	-
F29	20	Vacuum Pump

No.	Amps	Circuit protected
F30	-	-
F31	50	Cooling Fan Left-Hand
F32	50	Cooling Fan Right-Hand
F33	30	Electronic Park Brake Motor Left-Hand
F34	30	Electronic Park Brake Motor Right-Hand
F35	-	-
F36	20	Battery Main Relay
F37	15	Emission Control Systems
F38	15	Fuel Injection and Ignition - Left-Hand Bank
F39	15	Fuel Injection and Ignition - Right-Hand Bank
F40	10	Engine Ancillaries
R41	-	-
R42	-	Vacuum Pump relay
R43	-	Vacuum Pump relay

No.	Amps	Circuit protected
R44	-	Heated Rear Window
F45	10	Electrical Thermostats, Camshaft Actuators
F46	-	-
F47	-	-
F48	-	-
F49	-	-
R50	-	Fuel Pump 1
R51	-	-
R52	-	Fuel Pump 2
R53	-	Powertrain Chassis Control Unit
R54	-	Powertrain Chassis Control Unit
R55	-	Starter
R56	-	Secondary Air Pump
R57	-	Cooling Fans
R58	-	ECU Main relay Control

MAINTAINING YOUR McLAREN

FUSES

Secondary fuse box

Secondary fuse box access

1. Access to the secondary fuse box is gained by lowering the closing panel below the dashboard on the passenger's side.

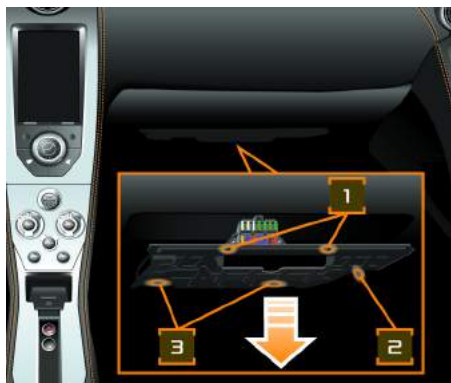

2. Remove the two front screws (1).
3. Remove the side fixing clip (2).

i *NOTE: If you wish to lower the closing panel fully, also remove the two clips at the rear (3).*

4. Lower the closing panel, sufficiently to gain access to the fuse box.

i *NOTE: Do not lower the closing panel further than necessary as it could be damaged.*

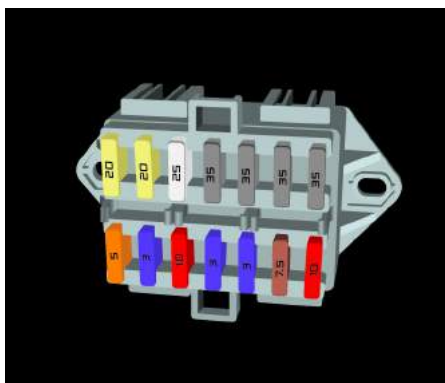

5. Remove the appropriate fuse and replace it with a fuse of the same value as the original. If in doubt, check the fuse specification chart.
6. Raise the closing panel into position, fit the clip and fit and tighten the two front screws.

Secondary fuse box fuse specification chart

No.	Amps	Circuit protected
F1	20	Driver's door
F2	20	Passenger's door
F3	25	Lights
F4	20	Lights
F5	35	Body
F6	35	Body
F7	35	Alarm
F8	5	Electronic Stability Control
F9	10	OBD2 Diagnostics
F10	10	Air conditioning
F11	3	Alarm Control Unit
F12	3	Tracker
F13	7.5	Alarm
F14	10	Instrument cluster

Battery fuse box

Battery fuse box access

1. Open the luggage compartment lid and remove any items stowed inside.



2. Remove the finisher (1) from around the top of the luggage compartment liner.
3. Remove the two stowage nets (2).
4. Remove the carpet (3).



5. Remove the 7 screws (4) securing the side and the base luggage compartment liner.
6. Remove the 10 screws (5) securing the top edge of the luggage compartment liner.
7. Remove the luggage compartment liner.

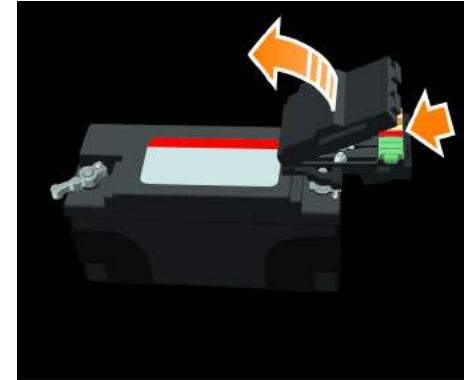

8. Press the 2 catches on the right-hand side of the cover and remove the cover from the fuse box.

MAINTAINING YOUR McLAREN

FUSES

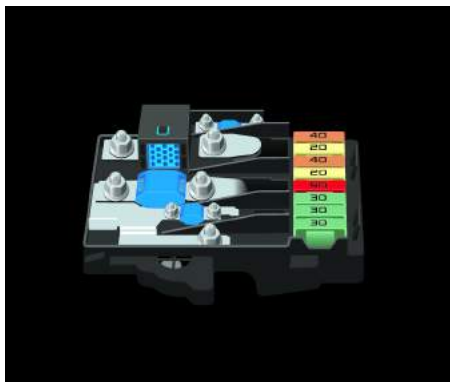

Battery fuse box fuse specification chart

No.	Amps	Circuit protected
1	-	-
2	-	-
3	30	Air Conditioning - Motor - Control Module
4	50	Secondary Fuse Box - Supply
5	20	Electronic Stability Control valves
6	40	Electronic Stability Control motor
7	20	Auxiliary Power Socket - Luggage Compartment
8	40	Secondary fuse box supply
9	100	Electro Hydraulic Power Assisted Steering
10	200	Main Fuse Box Supply
11	-	-

9. Remove the appropriate fuse and replace it with a fuse of the same value as the original. If in doubt, check the fuse specification chart.
10. Engage the left-hand side of the cover with the fuse box, and push the right-hand side down to fully engage the clips.
11. Refit the luggage compartment liner and secure with the 17 screws.
12. Fit stowage nets, carpet, and top finisher.
13. Stow the contents removed from the luggage compartment.

Vehicle lights

Lighting is an important aspect of vehicle safety. You must therefore ensure that all lights are working at all times.

All the external lights on your McLaren use the latest Light Emitting Diode technology.

Unlike traditional filament bulbs, these lights have a long life and low power consumption while providing the same amount of illumination.

Headlamps

Your McLaren is fitted with Light Emitting Diodes headlamps. These provide greater visibility on both dipped and main beams, especially during adverse weather and driving conditions.



NOTE: Do not attempt to change Light Emitting Diodes yourself, as you could damage the vehicle lighting systems. Have faulty lights rectified by your McLaren Retailer.

MAINTAINING YOUR McLAREN

MANUAL UNLOCKING AND OPENING

Unlocking - discharged battery

If you are unable to lock or unlock the vehicle because the vehicle battery or key fob battery has become discharged, use the mechanical key.

i *NOTE: In the event of an extremely low state of battery charge, the windows will lower slightly so that the left-hand door can be opened with the manual key. The alarm system will be disarmed to prevent the alarm sounding.*

Unlocking and opening procedure

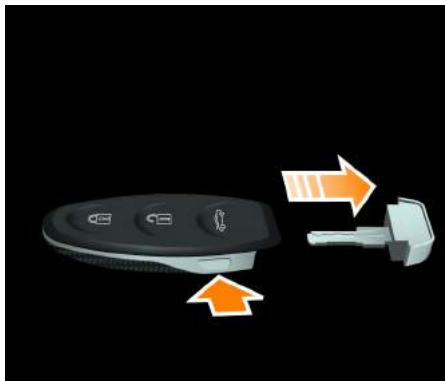

1. Press release catch and remove the mechanical key from the key fob.

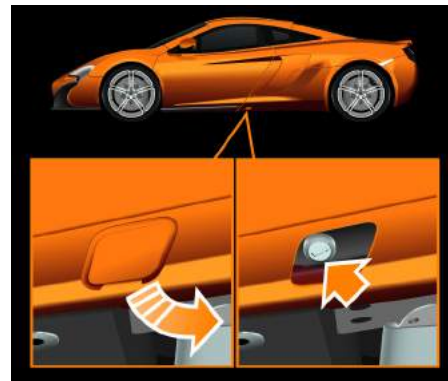

2. The mechanical lock is located below the door on the sill panel, underneath a removable panel.
3. Remove the panel by placing your fingers in the recess and pulling outwards.

i *NOTE: The panel is not tethered to the vehicle and can be removed completely. Ensure that the panel is stored safely and cannot be damaged when the mechanical key is used.*

4. Insert the mechanical key into the lock and turn the key until mechanical resistance is preventing full release of the door.
5. Apply pressure to the latch area of the door (to counteract pressure of the door seals), and turn the key further to release the door

i *NOTE: If the vehicle battery is discharged and if the windows have not lowered. Take care when opening or closing the door. Do not force the door open or closed, the door seals or window could be damaged.*

6. Fit the mechanical key back into the key fob.

i *NOTE: Unlocking the vehicle using the mechanical key will activate the anti-theft system and may cause the alarm to sound. Once the door is open, place the key fob on the section of the cup holder housing immediately behind the switch panel. within 10 seconds. The vehicle will recognise the key fob and stop the alarm from sounding.*

7. If the key fob battery has become discharged, replace the battery at the earliest possible opportunity, see Replacing key fob battery, page 5.27.
8. Replace the cover panel.

Starting the vehicle



If the key fob battery has become discharged, and the engine will not start, place the key fob on the section of the cup holder housing immediately behind the switch panel.

In this position the vehicle is able to sense the presence of the valid key fob and the vehicle can be started and driven.

Replace the key fob battery at the earliest possible opportunity, see Replacing key fob battery, page 5.27.

MAINTAINING YOUR McLAREN

MANUAL UNLOCKING AND OPENING

Door opening from inside - discharged battery



To release a door from inside, release the manual door release strap retainer and pull the strap.

The door latch will then release, allowing the door to be partially raised before it automatically swings outwards and upwards.

To refit the release strap, feed the strap into its holder and snap the retainers into place.

i *NOTE: Only use this strap when the battery has become discharged.*

i *NOTE: Please ensure that both of the retainers on the manual door release strap are fitted correctly, and in the correct positions on the B-Pillar after use.*

i *NOTE: Please ensure that the manual door release strap is fully retracted before fitting the retainers to their B-Pillar locations.*

Opening luggage compartment - discharged battery

i *The key fob or luggage compartment button on the centre console will not release the luggage compartment if the battery is discharged or disconnected. In the event of this use the manual release mechanism.*



Opening procedure

1. Pull the handle in the left-hand door aperture.
2. The luggage compartment will unlock and open slightly.
3. Release the safety latch and open the luggage compartment.

Replacing key fob battery

Fit a new key fob battery every 12 months. You can do this yourself, or entrust it to your McLaren Retailer.

When the key fob battery is discharged, you will only be able to unlock the vehicle with the mechanical key.

You will require a single CR2032 3V battery.

⚠ WARNING: The battery contains toxic substances. If a battery is swallowed, contact a doctor immediately.

♻ ENVIRONMENTAL: Do not dispose of the battery with the household waste. Batteries contain toxic substances.

Take the discharged battery to your McLaren Retailer or to a recycling point for used batteries.

MAINTAINING YOUR McLAREN

MANUAL UNLOCKING AND OPENING

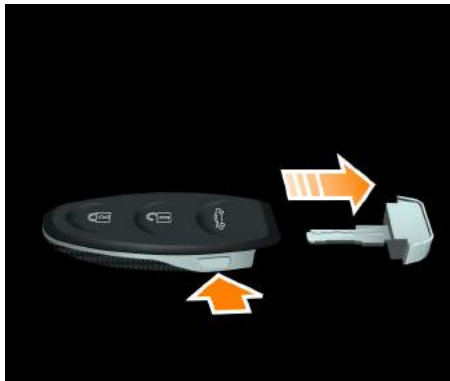

1. Press the release catch and remove the mechanical key from the key fob.



2. Slide the button pad away from the key fob.



3. Remove the back cover from the key fob and remove the battery holder.

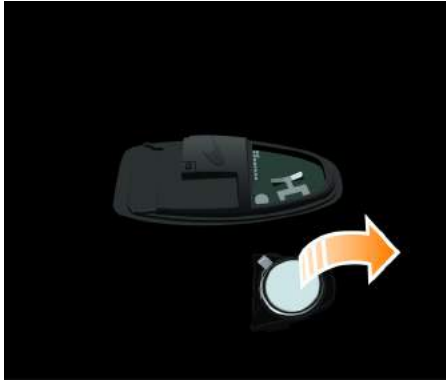

4. Remove the discharged battery from the battery holder and install a new battery ensuring that the polarity is correct.

i *NOTE: Handle the battery as little as possible. Moisture and oil from fingers can affect battery life and cause corrosion of the contacts. Only hold the battery on the edges.*

5. Fit the battery holder back into the key fob and replace the back cover.
6. Refit the button pad and the mechanical key.

Replacing the wiper blade

⚠ WARNING: Ensure the ignition is switched off before you replace the wiper blade. The windscreen wiper could be set in motion and injure you.

⚠ WARNING: Replace the wiper blade every twelve months or the windscreen will not be wiped properly. You may not be able to observe the road and traffic conditions as a result and could cause an accident.

To remove the wiper blade

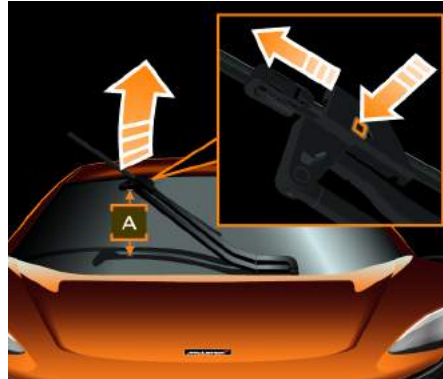

1. Press the **STOP/START** button twice to switch the ignition on but **DO NOT** touch the brake pedal.
2. Move the wiper control stalk to its slow speed setting.
3. Wait until the wiper blade is at the top of its stroke then press the **STOP/START** button to switch the ignition off and park the wiper blade on the windscreen.

i *NOTE:* Do not raise the end of the wiper arm more than 300 mm (12 inches), dimension A from the windscreen as the washer jet components may be damaged.

i *NOTE:* Never open the luggage compartment lid when the wiper arm is positioned away from the windscreen. You could damage the luggage compartment lid and/or the wiper arm. Do not lower the wiper arm onto the windscreen without the wiper blade fitted.

4. Depress the clip and slide the wiper blade out from the arm.

To install a new wiper blade

1. Slide the wiper blade onto the wiper arm and ensure that the clip engages in the arm.
2. Lower the wiper arm onto the windscreen.

Wheels and tyres



WARNING: Have worn tyres replaced in axle pairs and ensure the tyres are fitted as specified, see Tyres, page 5.32. With worn tyres, the driving stability of the vehicle will be adversely affected, especially when driving at high speeds.

Consult your McLaren Retailer if you have had new tyres fitted for information on the appropriate bedding in time based on your driving style.

- With new tyres, avoid high speed cornering and excess speed.
- Only have wheels and tyres of the same type and make fitted.
- Never use a tyre which has been punctured and then repaired.
- Only have tyres of the correct size fitted.
- Tyres degrade over time due to the effects of ultraviolet light, extreme temperatures, high loads, and

environmental conditions. It is recommended that tyres are replaced every six years, or sooner if required.

McLaren recommends that you only use Pirelli summer or winter tyres, See Wheel and tyre sizes, page 6.9.

These tyres provide the best possible performance in conjunction with the safety systems on your vehicle and have been specifically approved by McLaren.

McLaren cannot accept any responsibility for damage that may result from use of other tyres and wheels. Further information about wheels and tyres can be obtained from your McLaren Retailer.



WARNING: Using tyres other than those which have been recommended by McLaren, may contact the body work and adversely affect the handling. This may cause loss of vehicle control, resulting in serious personal injury or death. Noise levels and fuel consumption may also be adversely affected. In addition, when driving with a load or

when using snow traction devices, they could cause contact between the bodywork and axle components. This could result in damage to the tyres or the vehicle



NOTE: Retreaded tyres must not be used. Do not fit used tyres if you have no information about their previous usage.



NOTE: Modification to the brake system and wheels is not permitted, nor is the use of spacer plates or brake dust shields. Any such modifications will invalidate the vehicle warranty on the area modified.



NOTE: A wheel change must be carried out at your McLaren Retailer. The vehicle could be damaged if it is jacked up incorrectly



NOTE: Store tyres in a cool, dry place, preferably in the dark. Protect the tyres from oil, grease and petrol.

MAINTAINING YOUR McLAREN

WHEELS AND TYRES

Tyre markings

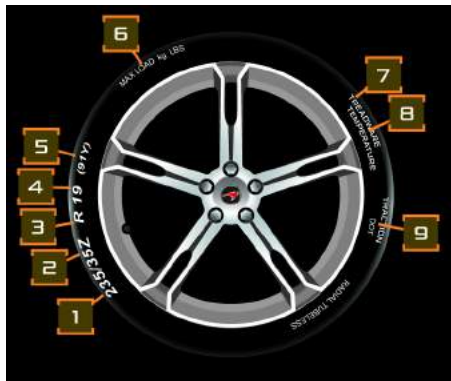

1. Width of tyre in millimetres
2. Tyre profile given as percentage of tyre width.
3. Indicates that the tyre is radial ply.
4. Indicates the diameter of the wheel rim in inches.
5. The numbers denote load index and the letter indicates the speed rating. 91 indicates a weight of 615 kg (1,350 lbs) and Y indicates speeds over 186 mph (300 kph).

6. Displays the maximum load which can be carried by the tyre
7. Wear rate indicator. The higher the figure the longer a tyre will last.
8. The alpha character denotes resistance to heat. An 'A' rated tyre offers most heat resistance.
9. Information about the manufacture of the tyre. Contains place and date of manufacture.

Tyres



WARNING: The tyres must be mounted according to the labelling on the tyre wall. The word 'OUTSIDE' must be on the outer edge of the tyre when it is fitted to the wheel or the stability of the vehicle will be adversely affected, especially at high speeds.

Asymmetric tyres



Asymmetric tyres have a tread pattern that is different from one side of the tread to the other. This combination of tread offers better grip in both wet and dry conditions.

The outer tread features a larger stiffer tread pattern that aids with cornering stability. The inner tread pattern aids stability in wet conditions. A central groove in the tyre aids straight line stability.

 **WARNING: Only tyres recommended by McLaren are to be fitted to the vehicle.**

 **WARNING: The tyres must be mounted according to the labelling on the tyre wall. The benefits of asymmetric tyres will only be available if the tyres are fitted correctly.**

Inspecting wheels and tyres

At least every 14 days, check the tyres for cuts, punctures, tears, bumps, deformation and cracks. Check wheels for severe corrosion. Damaged wheels could cause a loss of tyre pressure.

Regularly check the tyre tread depth and the condition of the tread across the whole width of the tyre. Turn the front wheels to full lock in order to inspect the inner tread.



When the tread is worn to 1.6 mm, the wear indicators appear on the surface of the tread pattern, producing a continuous band of rubber across the width of the tyre. Tyres must be replaced as soon as the wear indicator becomes visible, or sooner if legislation dictates replacement at a greater tread depth.

 **NOTE:** It is recommended that you always have your tyres replaced by your McLaren Retailer. If Tyre Pressure Monitoring System (TPMS) is fitted, each

wheel has a tyre pressure sensor connected to the tyre valve. In order to avoid damage to the sensor, the tyres must be replaced using the correct procedure.

 **WARNING:** Tyre grip decreases rapidly on wet or icy roads, particularly when the tread depth is close to the minimum. You could lose control of the vehicle and cause an accident due to the reduced grip of the tyres. Reduce your speed and drive with greater care.

 **NOTE:** If tread wear is uneven across the tyre, or becomes excessive, the wheel alignment should be checked.

Regularly check the pressure of all your tyres and correct the pressure as necessary, see Tyre pressures, page 5.34.

All wheels must have a valve cap fitted to protect the valve against dirt and moisture.

MAINTAINING YOUR McLAREN

WHEELS AND TYRES

Driving precautions

When parking your McLaren, ensure that the tyres do not contact the kerb or other obstacles. If it is necessary to drive over kerbs, speed humps or potholes, drive slowly and at a shallow angle or the tyres could be damaged.

While driving, pay attention to vibrations, noises and unusual handling characteristics, e.g. pulling to one side. This may indicate that the tyres or wheels are damaged. If you experience anything unusual, reduce your speed and stop the vehicle as soon as safety permits to check the tyres and wheels for damage. If you find no signs of damage, have the tyres and wheels inspected at your McLaren Retailer.

Tyre pressures

 **WARNING: Tyre pressure that is too high or too low has a negative effect on the vehicle's active safety, this could lead to an accident. Frequently check the pressure of all tyres, particularly prior to long trips, and correct the pressure as necessary.**

 **WARNING: If the pressure in a tyre drops repeatedly, inspect the tyre for foreign objects or signs of punctures, check the valve for air leaks.**



For the tyre pressures for various operating conditions, see Tyre pressures, page 6.9. They are also printed on a label attached to the fuel filler flap.

If the vehicle is to be driven at high speeds, the tyre pressure must be checked, and if necessary adjusted.

 *NOTE: In some markets, the tyre pressure label is attached to the driver's sill panel.*

 *NOTE: Tyre pressures given for low loads are minimum values which offer optimum ride comfort.*

Increased pressures for higher loads will not adversely affect the running of the vehicle, but ride comfort will be impaired.

Check the pressures when the tyres are cold. If it is necessary to check the tyres when they are warm, pressures will be higher. Do not let air out of warm tyres to match the recommended cold tyre pressures.

Driving with tyre pressure that is too high or too low can:

- create a risk of tyre failure with resultant accidents, causing injury or death
- shorten the life of the tyres
- cause increased tyre damage
- have a negative effect on handling characteristics (e.g. by causing aquaplaning)

 ENVIRONMENTAL: Check tyre pressures at least every 14 days.

Interchanging wheels

 **WARNING: Only approved wheels with winter tyres can be fitted to your McLaren as alternatives.**

Deflated tyre

Your McLaren is equipped with a can of tyre sealant, which is located in the luggage compartment.

In the event of a puncture, follow the steps below to ensure your safety and the safety of other vehicle occupants and other road users.

Repairing a puncture

1. Stop the vehicle as far away as possible from traffic and on a firm and level surface.
2. If on a public highway, switch on the hazard warning lamps, see Hazard warning lamps, page 1.52.
3. Passengers should exit the vehicle safely and remain well away from the vehicle, the road and any traffic.
4. Apply the parking brake and select neutral.
5. Place the warning triangle at an appropriate distance from the vehicle to warn other traffic of a breakdown, see Warning triangle*, page 5.10.

Using the tyre sealant

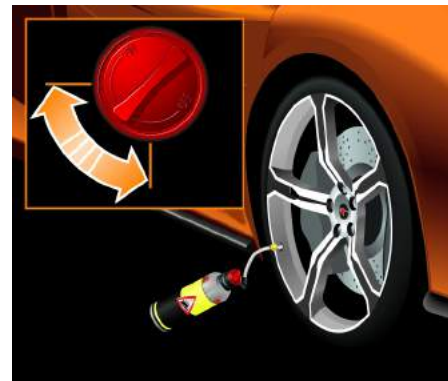

You can use the tyre sealant to seal small punctures, particularly those in the tyre's tread. The tyre sealant can be used at ambient temperatures down to -20°C (-4°F).

 **WARNING: The tyre sealant is unable to seal punctures if:**

- there are cuts or punctures in the tyre greater than 4 mm
- the rims are damaged

MAINTAINING YOUR McLAREN

WHEELS AND TYRES

- **you have driven at very low tyre pressures or with deflated tyres**

Contact your McLaren Retailer immediately.

Remove the tyre sealant from the luggage compartment and follow the instructions on the container.

 **NOTE:** *If possible, locate the cause of the puncture and position the wheel so the puncture is at the lowest point to enable the sealant to be more effective.*

Have the punctured tyre replaced as soon as possible.

 **WARNING:** **Have punctured tyres replaced. McLaren do not recommend that punctured tyres are repaired.**

 **WARNING:** **If the tyre sealant comes into contact with your eyes or skin, immediately rinse thoroughly with clean water, change out of clothing which has been in contact with the tyre sealant. If an allergic reaction occurs, contact a doctor immediately.**

 **WARNING:** **Keep the tyre sealant out of reach of children. If tyre sealant is swallowed, immediately rinse the mouth thoroughly and drink a large amount of water. Do not induce vomiting. Contact a doctor immediately. Do not inhale tyre sealant fumes.**

 **NOTE:** *After using tyre sealant, the tyre valve, incorporating the Tyre Pressure Monitoring System sensor*, will have to be replaced.*

Trofeo R tyres*

Pirelli offer Trofeo R tyres approved for use on your McLaren.

 **NOTE:** *Trofeo R tyres must be fitted with the Tyre Pressure Monitoring System (TPMS).*

The driver's skill level must be commensurate with the vehicle performance levels in the upper range limits due to increased safety risks.

 **NOTE:** *Due to ultra high performance design and the particular manufacturing process of these tyres, they must always be replaced in axle sets (Front and rear) regardless of wear or mileage. Failure to do so may have a negative affect on the handling characteristics of the vehicle.*

The main features of the Trofeo R tyres are a reduced tread depth and a special tread pattern and carcass compared with other tyres.



WARNING: Risk of accident from worn tyres. Trofeo R tyres have a smaller tread depth, and thus can reach their wear limit sooner. It is important to check tyre wear frequently to avoid risk of serious personal injury or death from worn tyres.



WARNING: Risk of accident through loss of road surface contact, control over the vehicle and braking ability, leading to serious personal injury or death. The reduced tyre tread depth means that there is an increased risk of hydroplaning on wet roads. When driving on wet or mud-covered roads reduce speed significantly.



NOTE: Notify anyone using your car of these characteristics and possible effects.

Washing your McLaren

 ENVIRONMENTAL: Some cleaning products contain chemicals that are hazardous to the environment. Always take precautions to prevent fluids from spilling and never use excessive quantities.

Using an automatic car wash



 NOTE: To prevent damage to your McLaren always heed the following:

- switch off the windscreen wiper
- press the central locking button to lock the vehicle before it enters the wash, to prevent inadvertent opening of a door
- on conveyor type car washes, switch on the ignition, engage neutral and release the parking brake

 NOTE: If using a car wash where your car will remain stationary during the wash cycle and you intend to exit the vehicle prior to washing, lock it using the key fob and stand well clear of the vehicle and the car wash, to ensure that the key fob is at least 3 metres (9.8 feet) or greater distance away from the vehicle and car wash.

 NOTE: After the wash, it is advised to drive the vehicle and warm the engine to dry off any excessive water from the engine.

Hand washing your McLaren

Prior to hand washing, lock the vehicle and place the key out of range (at least 3 metres (9.8 feet) or greater distance) to ensure that the doors do not open.

i *NOTE: Do not wash the vehicle in direct sunlight or if it is hot to the touch, this may cause water marks and streaks.*

Do not wash the engine with hose pipe or pressure washer.

Do not use household detergents, these products will discolour painted surfaces and remove protective wax finishes.

1. Pre-rinse the body thoroughly with a hose pipe held at a shallow angle to loosen any dirt and wet the paintwork ready for washing, avoiding direct spray on engine cover vents.
2. Prepare a bucket of warm water and a good quality car shampoo. Refer to the shampoo manufacturer's instructions for dilution ratios.
3. Working from the top of the vehicle down, wash the vehicle, ideally using a lambswool wash mitt rather than a

sponge, use generous quantities of water paying particular attention to areas where dirt can accumulate. Use one wash mitt for the top of the vehicle (roof, luggage compartment lid and areas above the wheel arch line) and a separate mitt for areas below the wheel arch line.

i *NOTE: Do not clean the wheels with these wash mitts.*

i *NOTE: Do not allow the shampoo to dry, it will leave streaks on the paint work.*

4. Tar spots and stubborn grease marks can be removed using white spirit or denatured alcohol. After cleaning, immediately wash the area with soapy water to remove all traces of spirit or alcohol.
5. Once the vehicle is clean, work from the top of the vehicle down and rinse the vehicle thoroughly using a hose pipe held at a shallow angle, avoiding direct spray on engine cover vents.
6. Dry the vehicle using a chamois leather or drying towel.

i *NOTE: In case of signs of water in the engine bay, it is advised to drive the vehicle and warm the engine to operating temperature to dry off any excessive water from the engine.*

Washing the wheels

i *NOTE: Wash the wheels frequently, do not allow brake dust to become ingrained in the wheel rim finish.*

Wash the wheels using warm water, a good quality car shampoo and a wheel brush or wash mitt that is used only on the wheels. Apply polish to non-satin finished wheels to assist in keeping them clean.

i *NOTE: Never apply polish to satin finish wheels, this will result in localised glossy patches on the surface of the wheel.*

i *NOTE: Do not use acid based wheel cleaners as these can damage the wheel rim finish leading to corrosion.*

i *NOTE: Ensure the brakes are fully dried after the wheels have been cleaned before the vehicle is stored.*

Wiper blades and rubber seals

Clean wiper blades and rubber seals using warm water and a good quality car shampoo only. Do not use petroleum or alcohol-based cleaners.

Windscreen, windows and mirrors

Regularly clean all windows inside and out using a window cleaning solution. An automotive glass cleaner is recommended. After washing the vehicle with car shampoo containing wax, clean the outside of the windscreen with glass cleaner. Do not use abrasive cleaning compounds as mirror glass is particularly susceptible to damage.

Underbody cleaning

Salt used on roads to control snow and ice during the winter can collect on the vehicle's underbody, if this is not removed, corrosion can occur. During the winter months, regularly hose the underbody with water paying particular attention to the wheel arches and areas where dirt can accumulate.

Polishing

Occasionally polish the paint work using a good quality polish, following up with a protective wax.



NOTE: Do not use cutting compound, colour restoration products or polishes containing a harsh abrasive. These can scratch the surface and permanently damage the paint work.

Paint damage and rectification

Regularly inspect the paint work for damage. Any stone chips or deep scratches should be repaired as soon as possible. Contact your McLaren Retailer for advice.

Cleaning the interior



NOTE: Your McLaren Retailer will be able to recommend products for cleaning the interior of your vehicle.

Carpet and fabrics

Before cleaning upholstery, always test the cleaning solution on a concealed area. Clean with diluted upholstery cleaner and a clean cloth.

Leather

Before cleaning leather, always test the cleaning solution on a concealed area. Clean with warm water and a non-detergent soap or a proprietary leather cleaner. Dry with a dry, clean, lint-free cloth. Do not use abrasive cleaning products or polish.

Do not polish the upper surfaces of the dashboard. Polished surfaces are reflective and may interfere with the driver's view. Clean with diluted upholstery cleaner, then wipe with a damp cloth.

Carbon Fibre

Before cleaning visible carbon fibre, always test the cleaning solution on a concealed area. Clean with a propriety matt dashboard cleaner. Contact your McLaren Retailer for more information. Do not use abrasive cleaning products or polish.

Alcantara®

Dust the material with care. Moisten a soft cloth or a sponge with water, wring it thoroughly and run it over the whole Alcantara® material. Make sure not to wet it excessively; rinse the cloth or sponge and repeat as necessary.

Leave the material to dry overnight.

Once the material has dried, in order to restore the material, brush it delicately with a soft bristle brush.

Seat belts

Extend the belts and clean with warm soapy water only. Do not use any type of detergent or chemical cleaning product. Allow the belts to dry naturally while extended, preferably away from direct sunlight.

Instruments and display screens

Clean the instrument cluster using a damp cloth. Do not use abrasive cleaning products or polish.

MAINTAINING YOUR McLAREN

RAISING THE VEHICLE

Vehicle lifting points

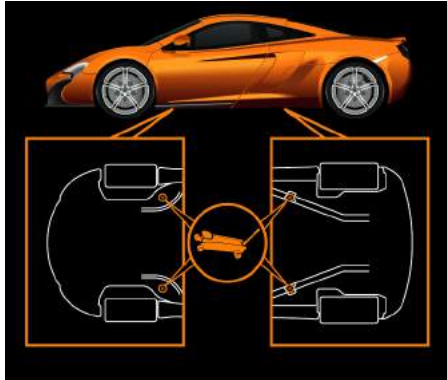

Refer to the illustration, and labels on the vehicle, for correct lifting locations.

Make this information available to any third parties who may be assisting in the recovery of your McLaren.

i *NOTE: Lifting the vehicle at any other points will damage the vehicle.*

i *NOTE: Use a jack with a flat lifting platform and a rubber pad to protect the chassis from surface damage. Do not lift under a body panel.*



WARNING: Ensure the vehicle is correctly positioned on a jack or vehicle lift before raising the vehicle to a workable height. Always engage vehicle lift safety locks or use suitable stands to ensure your safety before working under the vehicle.

McLaren Assistance

If your McLaren is immobilised, do not attempt to make your own arrangements for assistance.

Refer to your Service and Warranty documentation, this contains all the information you need.

Replacement battery

If your McLaren has been immobilised due to a fault with the vehicle battery, it is possible for your McLaren Retailer or the Assistance provider to fit a lead acid battery as an emergency short term solution.

 *NOTE: If a lead acid battery is fitted, it must be replaced with the correct specification lithium ion battery at the earliest opportunity.*

You will also notice error messages appearing in the left-hand display.

In the event of a breakdown

In the event of a problem with your vehicle, contact your McLaren Retailer. If your McLaren Retailer is unavailable, contact the Roadside Assistance Operator who is available 24 hours a day, 7 days a week.

 *NOTE: The contact details of your Roadside Assistance Operator can be found in your Service and Warranty booklet.*

The McLaren Retailer or Roadside Assistance Operator will verify your identity and that of your vehicle, as well as determining your exact location.

They will then discuss the problem with you and, with your agreement, determine the best solution.

Towing for recovery

Your McLaren is equipped with a front towing eye mounting only.

i *NOTE: Do not tow the vehicle, doing so could damage the gearbox. The towing eye must only be used to winch the vehicle onto a trailer or transporter for recovery purposes.*

Do not use a rigid bar to tow the vehicle.

Towing eye and mounting

The towing eye is located at the front of the luggage compartment.

1. Remove the cover from the towing eye mounting in the front bumper.



2. Screw the towing eye clockwise into the mounting hole, ensuring that it is screwed in to the full extent of the thread.

i *NOTE: To avoid damage to the towing eye and the vehicle, it is important to ensure that the towing eye is in full contact with the mating surface of the front structure.*

i *NOTE: A winch cable/strap must be secured to the towing eye only or the vehicle could be damaged.*

3. Remove the towing eye, stow it in the luggage compartment and refit the cover to the towing eye mounting as soon as the vehicle has been recovered.

Driving abroad

McLaren Retailers are also at your disposal when you are travelling abroad.

The legal requirements when driving abroad vary from country to country and are constantly changing. Always seek advice from your McLaren Retailer regarding what is required to remain legal in the countries in which you are travelling.

In certain countries, only low-octane fuel is available. For further information about fuel grades, see Recommended fuel, page 2.52.



NOTE: The headlamp asymmetric dipped beam is designed to light up the near side of the road more intensely. On your McLaren, the same headlight dipped beam setting applies for driving on either the left hand or right hand side of the road.



GENUINE McLAREN PARTS AND ACCESSORIES

Overview..... 6.2

VEHICLE IDENTIFICATION

Vehicle identification number..... 6.3

DATA

Overview..... 6.4

Vehicle operating temperatures 6.4

Engine 6.4

Maximum speeds in each gear..... 6.5

Gear ratios..... 6.5

Vehicle dimensions..... 6.6

Vehicle weights..... 6.7

Wheel and tyre sizes 6.8

Turning circle..... 6.8

Tyre pressures..... 6.8

SERVICE PRODUCTS, FLUIDS AND CAPACITIES

Service products 6.9

Engine oil specification 6.9

Fuel..... 6.9

Coolant..... 6.10

Power steering fluid..... 6.10

Brake fluid 6.10

TECHNICAL GLOSSARY

Technical glossary 6.11

Overview

McLaren recommends that you only use genuine McLaren replacement parts and accessories. The use of non-genuine parts could have a detrimental effect on the vehicle's operation and safety. McLaren tests replacement parts and accessories, for reliability, safety and suitability. McLaren accepts no responsibility for the use of non-genuine parts on their vehicles, even if they have been independently approved.

In many countries, replacement parts and accessories are only officially approved for installation if they comply with legal requirements. All genuine McLaren replacement parts and accessories meet these requirements.

Genuine McLaren parts and accessories can be obtained from your McLaren Retailer where the parts will be professionally fitted.

Ensure that any accessories are suitable for your McLaren. Accessories which constitute a modification to the vehicle could invalidate the vehicle's warranty. This applies if they:

- change the vehicle type approved in the warranty
- could endanger road users
- adversely affect the vehicle's emissions and noise levels

Always quote the vehicle identification number, you will find this on the vehicle identification plate, and in the bottom left-hand corner of the windscreen.

Vehicle identification number



The vehicle identification number can be found on the bottom left-hand corner of the windscreen.

The number can also be found engraved on the body behind the right-hand seat, stamped on a plate at the base of the driver's side B-post and viewed in the Vehicle Info section in the left-hand display, see Vehicle identification, page 3.19.

VIN plate



The vehicle identification number plate also contains the following:

- maximum permitted laden weight
- maximum permitted laden weight including trailer
- maximum permitted front axle laden weight
- maximum permitted rear axle laden weight

Overview

This section contains all the necessary technical data for your vehicle and applies to the vehicle's standard equipment. The data may therefore differ for vehicles with optional equipment. You can obtain further information from your McLaren Retailer.

Vehicle operating temperatures

Minimum ambient operating temperature	-20°C (-4°F)
Maximum ambient operating temperature	+50°C (+122°F)

i *NOTE: If the vehicle is used outside the minimum and maximum ambient temperatures, performance degradation may be experienced. McLaren disclaims any liability of the stated engine power not being achieved if the vehicle is being used outside of the stated temperature ranges or being used at altitude.*

Engine

Engine - 650S	
Rated output (kW) @rpm	478 @ 7,250
Rated output (PS) @rpm	650 @ 7,250
Rated torque (Nm) @rpm	678 @ 6,000 [95% 3000-7000]
Rated torque (lb-ft) @rpm	500 @ 6,000 [95% 3000-7000]
Number of cylinders	8
Displacement cm ³	3,799
Maximum engine speed (rpm)	8,500
Power to weight ratio (PS/tonne)	500 - Coupe 485 - Spider
Acceleration (0 to 100 kph) (s)	3.2 (3.0 Corsa tyres)
Acceleration (0 to 60 mph) (s)	3.1 (2.9 Corsa tyres)

VEHICLE DATA AND GLOSSARY

DATA

Maximum speeds in each gear

1st gear (mph (kph))	50 (80)
2nd gear (mph (kph))	77 (124)
3rd gear (mph (kph))	106 (170)
4th gear (mph (kph))	137 (220)
5th gear (mph (kph))	175 (282)
6th gear (mph (kph))	208 (335) - Coupe 205 (331) - Spider
7th gear (mph (kph))	193 (312) - Coupe 192 (309) - Spider

Gear ratios

1st gear	3.981:1
2nd gear	2.613:1
3rd gear	1.905:1
4th gear	1.479:1
5th gear	1.161:1
6th gear	0.906:1
7th gear	0.686:1
Final drive	3.308:1

VEHICLE DATA AND GLOSSARY

DATA

Vehicle dimensions

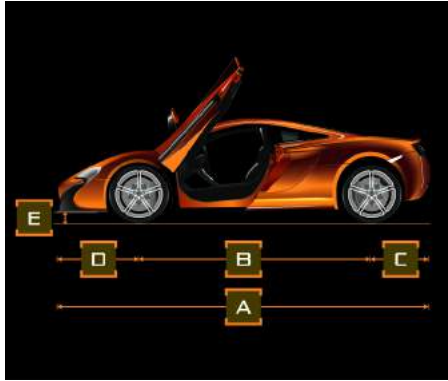

A	Vehicle length	4,512 mm (14 ft 10 in)
B	Wheelbase	2,670 mm (8 ft 9 in)
C	Rear overhang	786 mm (2 ft 7 in)
D	Front overhang	1,056 mm (3 ft 6 in)
E	Ground clearance	120 mm (5 in)

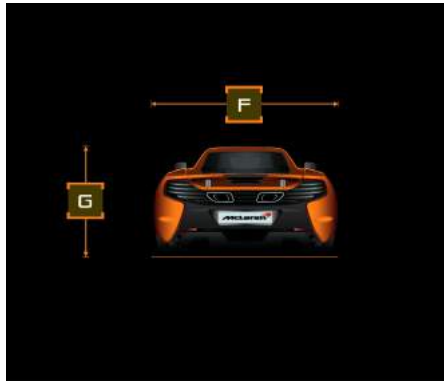

F	Vehicle width (doors closed, including mirrors)	2,093 mm (6 ft 11 in)
G	Vehicle height (doors closed)	1,199 mm (4 ft) - Coupe 1,203 mm (4 ft) - Spider

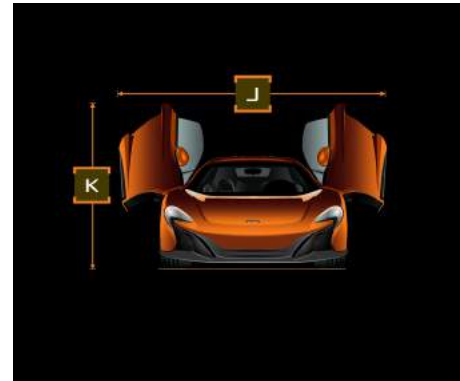

J	Vehicle width (doors open at widest point)	3,087 mm (10 ft 2 in)
K	Vehicle height (doors open)	1,892 mm (6 ft 3 in)



NOTE: All dimensions are approximate.

VEHICLE DATA AND GLOSSARY

DATA

Vehicle weights

Weight - 650S	
Dry weight (kg (lbs))	1,330 (2,932) - Coupe 1,370 (3,020) - Spider
Unladen weight (all fluids and 90% fuel) (kg (lbs))	1,428 (3,148) - Coupe 1,468 (3,236) - Spider
Kerb weight (plus 75 kg driver) (kg (lbs))	1,503 (3,313) - Coupe 1,543 (3,401) - Spider
Kerb weight distribution - front axle (kg (lbs))	607 (1,338) - Coupe 617 (1,360) - Spider
Kerb weight distribution - rear axle (kg (lbs))	821 (1,810) - Coupe 851 (1,876) - Spider

Weight - 650S	
Maximum gross vehicle weight (GVW) (kg (lbs))	1,690 (3,726) - Coupe 1,747 (3,852) - Spider
Maximum gross vehicle weight distribution - front axle (kg (lbs))	727 (1,603) - Coupe 751 (1,656) - Spider
Maximum gross vehicle weight distribution - rear axle (kg (lbs))	963 (2,123) - Coupe 996 (2,196) - Spider
Maximum load - luggage compartment (kg (lbs))	50 (110) - Coupe 50 (110) - Spider
Maximum load - Tonneau stowage area (kg (lbs))	30 (66) - Spider only

VEHICLE DATA AND GLOSSARY

DATA

Wheel and tyre sizes

Wheel sizes

Front wheels	8.5J x 19
Rear wheels	11J x 20

Summer tyres

Front tyres	
- Pirelli PZero MC1	235/35 R19
- Pirelli Corsa MC1	235/35 R19

Rear tyres	
- Pirelli PZero MC1	305/30 R20
- Pirelli Corsa MC1	305/30 R20

Winter tyres

Front tyres	
- Pirelli SottoZero 3	235/35 R19

Rear tyres	
- Pirelli SottoZero 3	305/30 R20

Turning circle

Turning circle kerb-to-kerb	12.3 metres (41 ft)
--------------------------------	---------------------

Tyre pressures



The tyre pressures are given below and can also be found on a label on the underside of the fuel filler flap.

Loading condition	Front wheels		Rear wheels	
	Bar	Psi	Bar	Psi
Normal use	2.0	29	2.2	32
Speeds over 165 mph (270 kph)	2.6	38	2.8	41

VEHICLE DATA AND GLOSSARY

SERVICE PRODUCTS, FLUIDS AND CAPACITIES

Service products

Service products are fuel, engine oil, coolant and brake fluid. McLaren recommends that you only use products tested and approved for McLaren. Damage resulting from using non-approved service products is not covered by the liability for material defects.

 **WARNING: When handling, storing and disposing of any service products, please observe the relevant regulations. Failure to do so could endanger people and the environment. Do not allow service products to come into direct contact with your eyes or open wounds. Contact a doctor immediately if any service product is swallowed.**

 ENVIRONMENTAL: Dispose of service products in an environmentally responsible manner.

Engine oil specification



Engine oil capacity	8.0 litres
---------------------	------------

 *NOTE: McLaren recommends only Mobil 1 New Life 0W-40 engine oil.*

You may obtain further information from your McLaren Retailer.

 *NOTE: Do not use any lubricant additives. These could lead to increased wear and damage to the mechanical assemblies. Damage caused by additives, which are not approved, is not covered by the McLaren warranty.*

Fuel

 **WARNING: Fuel is highly flammable. Fire, naked flames and smoking are therefore prohibited when handling fuels.**

Switch off the engine before refuelling.

 **WARNING: Do not allow fuel to come into contact with skin or clothing.**

Allowing fuels to come into direct contact with your skin or inhaling fuel vapours is damaging to your health.

For more information about fuel, see Recommended fuel, page 2.52.

Fuel tank

Total capacity	72 litres (15.8 UK gal.)
Capacity remaining when low level lamp illuminates	11 litres (2.4 UK gal.)

Coolant

Cooling system capacity	26.0 litres (5.7 UK gal.)
Antifreeze/corrosion inhibitor	Mobil Extra Antifreeze
Antifreeze quantity for protection to -20°C (-4°F)	13.0 litres (2.9 UK gal.)

The coolant is a mixture of water, antifreeze and corrosion inhibitor. It performs the following functions in the cooling system:

- antifreeze protection
- increased efficiency of the cooling system
- offers anti-corrosion protection

 **NOTE:** Use Mobil Extra Antifreeze in all climates, all year round. If coolant is not used, the cooling system will not be sufficiently protected from corrosion and the cooling system efficiency will be reduced.

 **NOTE:** To prevent damage to the engine, only top-up with a pre-mixed coolant that provides the desired level of antifreeze protection.

If antifreeze/corrosion inhibitor is present in the correct concentration, the boiling point of the coolant will be around 130°C (266°F). The antifreeze and corrosion inhibitor concentration in the cooling system should be approximately 50% ±5%. This will protect the cooling system against freezing in temperatures of -40°C (-40°F).

The antifreeze and corrosion inhibitor concentration in the cooling system should not exceed 55%, which provides antifreeze protection down to -45°C (-49°F), as a higher concentration will not dissipate heat so effectively.

If the vehicle is losing coolant, do not drive your vehicle and contact your McLaren Retailer.

Power steering fluid

Only use Pentosin CHF202 power steering fluid.

Brake fluid

Only use Pentosin DoT 5.1 Brake fluid.

Over a period of time, the brake fluid absorbs moisture from the air, this reduces its boiling point.

 **WARNING:** If the boiling point of the brake fluid is reduced too much, vapour pockets may form in the brake system when the brakes are applied hard (e.g. when driving downhill or track driving) impairing the braking efficiency. Therefore, have the brake fluid replaced at the recommended service intervals.

Technical glossary

Active dynamics control

A system that allows the driver to change the handling and performance characteristics of the vehicle.

Airbrake

The Airbrake is a moveable wing that enhances the vehicle's driving stability and braking performance by increasing rear downforce.

Anti-lock Braking System

The Anti-lock Braking System prevents the wheels from locking when you brake. This allows the vehicle to be steered during braking manoeuvres.

Automatic Driver Recognition cards

A card which must be on the person entering the vehicle or the Tracker system signals that the vehicle is being moved without authorisation.

Brake assist system

Brake assist system operates in emergency braking situations. If you depress the brake pedal quickly, Brake assist system

automatically increases the force being applied to the brakes and thus shortens the stopping distance.

Brake disc wiping

Brake disc wiping operates when the windscreen wiper is switched on. It prevents moisture build up on the brake discs during periods of heavy rain, by applying the brakes momentarily, so that the pads touch the discs.

Brake steer

Brake steer offers the benefits of a torque vectoring differential, but is integrated into the braking system reducing weight and providing excellent speed of response.

If the system detects that the car is starting to understeer through a corner, the inside rear brake is gently applied. This helps to increase the yaw rate of the car, making the car feel more resistant to understeer. The lateral 'g' force is also increased giving better handling characteristics.

If the driver uses too much throttle exiting a corner, the inside rear wheel increases speed, which without brake steer could cause the car to become unstable. In this situation, brake steer will again gently apply the brake on the inside rear wheel, thereby restoring traction and stability.

Cylinder cut

When calling for an upshift at moderate engine speeds under hard acceleration within Sport powertrain mode, the number of firing engine cylinders are cut to rapidly decrease the engine torque and engine speed allowing faster upshifts to be achieved. This will make the upshift more audibly noticeable than a normal upshift. This also occurs in Track powertrain mode, but at high engine speeds it is replaced by inertia push. See Inertia push, page 6.12.

Electronic brake pre-fill

If the accelerator pedal is suddenly released, the electronic brake pre-fill function immediately brings the brake pads into contact with the discs, making for more rapid braking.

Electronic Stability Control

ESC monitors driving stability and traction between the tyres and the road surface.

Global Positioning System

By means of the appropriate receivers, satellite signals supply information on the geographical position of the vehicle. These signals are compared with a digital map and used both to determine the position of the vehicle and for its route guidance.

Handling control

The handling control switch affects the following vehicle characteristics:

- Roll stiffness
- Adaptive damping
- ESC settings

Hill hold control

Hill hold control prevents roll-back on hill starts. The brake system automatically applies the brakes until the accelerator is pressed.

Inertia push

Within Track powertrain mode when calling for an upshift at high engine speeds under hard acceleration, inertia push put simply delivers greater acceleration. Under normal driving conditions, outside of inertia push when maximum performance is not called for, the engine and transmission speeds are aligned for a smooth seamless upshift. However, with inertia push, the clutch holding the next gear is engaged with greater force and the engine speed is not allowed to decrease fully, therefore utilising the inertia of its internal rotating masses. This in turn provides a torque impulse as the gear is engaged aiding acceleration and maximising performance.

Launch control

Launch control is designed to give the maximum acceleration performance from a standing start.

Parking sensors*

The parking sensor system comprises four ultrasonic sensors in the front bumper, four ultrasonic sensors in the rear bumper and two

sounders. When the parking sensors detect an obstructions while manoeuvring, the sounders provide an audible warning.

Rear View Camera*

The Rear View Camera (RVC) is mounted in the centre of the rear grille. The live video feed is displayed on the IRIS screen when the function is active.

Pre-cog

'Pre-cog' (or 'pre-cognition') means 'fore knowledge'. When the appropriate paddle is pulled to the first pressure point, this informs the gearbox of an impending gear change. The gearbox then prepares for that change, and when it is required, the change is performed instantaneously.

Keyless Entry

Keyless Entry allows the driver to unlock the vehicle and disarm the alarm by simply opening the door when the key is within 1.5 metres (5 feet) of the door sensors.

Seamless Shift Gearbox

The seamless shift gearbox is a 7 speed, dual clutch gearbox. Gear changes can be fully automatic or driver controlled. The gear changes are almost instantaneous. It is this coupled with uninterrupted torque delivery from the engine which provides the relentless acceleration.

Supplementary Restraint System

System comprises a number of air bags which are automatically deployed in an accident to provide additional occupant protection.

Tyre Pressure Monitoring System*

Tyre Pressure Monitoring System constantly checks the pressure and temperature in all four tyres. It warns if the pressure drops or the temperature rises in one or more of the tyres.

Vehicle Identification Number

The vehicle identification number is a unique 17 digit number which provides information about your vehicle, as well as when and where it was built.

**Typical vehicle identification number =
SBM11AAA5AW00001**



A

Accelerator pedal position	2.19
Accessories	6.2
Active dynamics panel	2.23
active button	2.23
handling control	2.24
launch control	2.29
powertrain control	2.26
winter mode	2.28
Active speed limiter	2.47
setting an upper speed limit	2.47
Air bags	1.39
child passengers	1.44
deployment	1.42
front air bags	1.40
occupant classification system	1.41
Out Of Position (OOP) testing	1.43
replacement of air bags	1.39
side head air bags	1.40
system modification	1.40
Air conditioning	4.4
automatic mode	4.5
calibration	4.11
manual mode	4.6
MONO mode	4.6
switching on/off	4.5

Air conditioning controls	4.4
air distribution	4.9
air recirculation mode	4.10
air vents	4.9
blower speed	4.8
demisting	4.9
driver's	4.4
passenger's	4.5
temperature	4.7
Air distribution - air conditioning	4.9
Air vents	4.9
Airbrake	2.36
manual test	2.39
Alarm	1.24
arming	1.24
disarming	1.24
panic	1.53
Anti-lock Braking System	2.31
Anti-trap protection - windows	4.3
Automatic light control	1.49
Automatic locking	1.10
Automatic mode - transmission	2.19
Automatic wipe	1.54

B

Backlight	1.17
closing	1.18
opening	1.17
operation	1.17
Battery fuse box	5.22
fuses	5.22
Battery replacement - key fob	5.28
Battery safety	5.14
Belts - seat	1.37
Blower speed - air conditioning	4.8
Boost starting	5.15
Brake assist system	2.32
Brake disc wiping	2.32
Brake fluid	6.10
topping-up	5.8
Brake pedal	2.10
Brakes	
Anti-lock Braking System	2.31
Anti-lock Braking System warning light	2.32
bedding-in	2.48
brake assist system	2.32
brake disc wiping	2.32
brake steer	2.33
electronic brake pre-fill	2.33
foot	2.10

hill hold control	2.33
parking	2.8
warning light	2.10
Brake-steer	2.33
Breakdown	5.44
Bulb replacement	5.24
Bulkhead stowage net	4.17

C

Calibration - air conditioning	4.11
Camera	2.15
rear view	2.15
Capacities	6.9
cooling system	6.10
engine oil	6.9
fuel tank	6.9
Car cover	4.22
Catalyst	2.14
high temperature	2.14
Catalytic converter	2.14
Changing wheels	5.36
Checking engine oil	5.2
Child passengers	1.44
Child restraint system	1.44
KISI child seat function	1.45

Cleaning	5.39
exterior	5.39
instruments and display screens	5.42
interior	5.41
wheels	5.40
Clock	3.25
Closing the backlight	1.18
Closing the engine cover	1.12
Closing the luggage compartment	1.13
Closing the roof	1.16
Closing the windows	4.2
Coolant	6.10
topping-up	5.6
Copyright	3
Cover - engine	1.11
closing	1.12
opening	1.11
Cruise control	2.43
cancelling	2.44
decreasing speed	2.45
increasing speed	2.45
resuming speed	2.46
setting	2.43
Cup holder	4.20

D

Data	6.4
Date display	3.25
Daytime running lamps	1.51
Defrosting	4.9
Demisting	4.9
Deployment - air bags	1.42
Dimensions	6.6
Dipped beam headlamps	1.50
Direction indicators	1.52
Discharged battery	1.4
Discharged key fob battery	5.28
starting the engine	5.26
Display messages	
Coupe and Spider	3.26
Spider only	3.30
Display screen cleaning	5.42
Door mirror heating	1.47
Doors	1.2
automatic locking	1.10
closing from outside	1.10
locking	1.6
locking and unlocking from inside	1.8
manual opening from inside	5.27
opening from inside	1.9
opening from inside - discharged battery	5.27

opening from outside	1.5
Drink holder	4.20
Driver's air conditioning controls	4.4
Driving abroad	5.46
Driving away	2.12
Driving in winter	2.53
Driving precautions	5.35
Driving safety systems	2.31

E

Economical driving	2.13
Electric seats	1.29
backrest rake adjustment	1.30
forward and rearward adjustment	1.29
height adjustment	1.30
lumbar adjustment	1.31
Electric seats and mirror memory	1.31
Electrical status	2.2
Electronic brake pre-fill	2.33
Electronic Stability Control	2.34
deactivating	2.34
reactivating	2.36
Emergency fuel filling funnel	5.13
Engine	2.10
immobiliser	1.24
power output	6.4
running in	2.48

starting	2.10
stopping	2.11
technical data	6.4
warning light	2.13
Engine cover	1.11
closing	1.12
opening	1.11
Engine oil	5.2
capacity	6.9
checking	5.2
level warnings	5.2
specification	6.9
temperature warnings	5.5
topping-up	5.3
usage	5.2
Entry lighting	4.16
Equipment	5.11
luggage compartment	5.11
Exhaust	2.14
temperature monitoring	2.14
Exit lighting	4.17
Exterior lighting	1.48
Exterior mirrors	1.46
heating	1.47
memory	1.31
mirror automatic fold	1.47
mirror fold	1.47
reverse dip	1.47

Extinguisher	5.13
Eye - towing	5.13

F

Features	4.16
12V Socket	4.21
stowage compartment	4.19
stowage net	4.17
sun visors	4.19
Filling with fuel	2.50
Fire extinguisher	5.13
First aid kit	5.12
Fluid - brake	6.10
topping-up	5.8
Fluid - power steering	6.10
topping-up	5.7
Foot brake	2.10
Force limiters - seat belts	1.38
Front air bags	1.40
Fuel	2.50
funnel	5.13
level display	3.35
quality	2.52
safety	6.9
tank	6.9
Funnel - fuel	5.13

Fuse box	
main	5.18
secondary	5.21
Fuses	5.18
battery fuse box	5.22
main fuse box	5.18
replacement	5.18
secondary fuse box	5.21

G

Gear position indicator	3.33
Gear positions	2.6
Gear ratios	6.5
Gear Shift Indicator	2.13
Gearbox	2.18
gear positions	2.18
gearshift paddles	2.21
kickdown	2.19
modes	2.19
oil topping-up	5.5
pre-cog	2.22
Gearbox mode indicator	3.25
Genuine McLaren parts and accessories	6.2
Glossary - technical	6.11

H

Handling control	2.24
Hazard warning lamps	1.52
Headlamps	1.50
flash	1.50
main beam	1.50
Heated rear screen	4.11
Heated seats	1.33
Hill hold control	2.33
Horn	1.36

I

Identification number - vehicle	6.3
Ignition - switching on	2.3
Immobiliser	1.24
In gear speeds	6.5
Increasing vehicle ground clearance	1.56
Increasing vehicle ride height	1.56
Individual unlock settings	1.8
Inspecting tyres	5.34
Inspecting wheels	5.34
Installing luggage bags	1.21
Installing stowage bags	1.22
Instruments	3.2
cleaning	5.42
clock	3.25

display messages - Coupe and Spider	3.26
display messages - Spider only	3.30
display window	3.33
fuel level display	3.35
gear position indicator	3.33
gearbox mode indicator	3.25
handling and powertrain display	3.33
home screen	3.6
left-hand display	3.3
oil temperature display	3.34
overview	3.2
right-hand display	3.33
settings	3.7
speedometer	3.2
tachometer	3.2
trip computer	3.21
vehicle info	3.17
vehicle lift	3.22
water temperature display	3.35
Interchanging wheels	5.36
Interior accessory power socket	4.21
Interior lighting	4.16
courtesy lighting	4.16
Interior mirror	1.46
Interior motion sensor	1.26
Introduction	2

J

Jacking the vehicle	5.43
Journey trip	3.21
Jump starting	5.15

K

Key fob	1.2
entry	1.2
stowing	1.4
Key fob battery replacement	5.28
Keyless entry	1.2
Kickdown	2.19
Kit - first aid	5.12
Kit - tyre repair	5.36

L

Lamps - side	1.50
Launch control	2.29
Left-hand display	3.3
clock	3.25
home screen	3.6
messages - Coupe and Spider	3.26
messages - Spider only	3.30
overview	2.4
settings	3.7

trip computer	3.21
vehicle info	3.17
vehicle lift	3.22
Lifting points - vehicle	5.43
Light switch	1.49
Lighting	1.48
automatic control	1.49
courtesy lighting	4.16
day time running lamps	1.51
dipped beam	1.50
direction indicators	1.52
exterior	1.48
hazard warning	1.52
headlamp flash	1.50
interior	4.16
main beam	1.50
parking lights	1.53
rear fog lamp	1.51
sidelamps	1.50
switch	1.49
Limphome	2.13
Locking	1.6
automatic	1.10
from inside	1.8
mislock	1.7

Luggage compartment	1.12
closing	1.13
manual opening	5.28
opening - discharged battery	5.28
unlocking and opening	1.12
Luggage compartment equipment	5.11

M

Main beam	1.50
Main fuse box	5.18
fuses	5.18
Main instruments overview	2.4
Manual mode - air conditioning	4.6
Manual mode - transmission	2.19
Manual seat backrest adjustment	1.28
Manual seats	1.27
backrest rake adjustment	1.28
forward and rearward adjustment	1.27
height adjustment	1.28
Manual test - Airbrake	2.39
Manual unlocking	5.25
McLaren Assistance	5.44
McLaren parts and accessories	6.2

Mirror	1.46
automatic exterior mirror fold	1.47
exterior	1.46
exterior mirror fold	1.47
heating	1.47
interior	1.46
memory	1.31
reverse dip	1.47
Mislock	1.7
Motion sensor - interior	1.26

Q

Odometer	3.6
Oil - engine	5.2
capacity	6.9
checking	5.2
level	5.2
level warnings	5.2
specification	6.9
temperature display	3.34
temperature warnings	5.5
top-up	5.3
Oil - gearbox	5.5
Opening a door	1.5
from inside	1.9
from outside	1.5
Opening and closing the tonneau cover ..	1.19

Opening and closing the vents	4.9
Opening the backlight	1.17
Opening the engine cover	1.11
Opening the roof	1.15
Opening the windows	4.2
Operating temperatures - vehicle	6.4
Outside temperature display	3.6
Owner documentation	4.20

P

Panic alarm	1.53
Parking brake	2.8
Parking lights	1.53
Parking sensors	2.14
Parts	6.2
Passenger's air conditioning controls	4.5
Passenger's footwell stowage net	4.17
Passengers - child	1.44
Power output	6.4
engine	6.4
Power steering fluid	6.10
topping-up	5.7
Powertrain control	2.26
Precautions - driving	5.35
Pressures - tyre	5.35, 6.8
Products - service	6.9
Puncture repair kit	5.36

Q

Quick guide	4.20
-------------------	------

R

Racing seats	1.28
adjustment	1.28
Rain sensor	1.54
Ratios - gear	6.5
Reading lights	4.16
Rear fog lamp	1.51
Rear screen heating	4.11
Rear spoiler	2.36
Rear View Camera	2.15
Recirculation mode - air conditioning	4.10
Recommended fuel quality	2.52
Recovery of your vehicle	5.45
Refuelling	2.50
Removing and storing stowage bags	1.23
Replacement battery	5.44
Replacing	
bulbs	5.24
fuse	5.18
key fob battery	5.28
wiper blade	5.31

Restraint system	1.39	fuel	6.9	electric seat lumbar adjustment	1.31
child	1.44	mirrors	1.46	heated seats	1.33
KISI child seat function	1.45	replacement of air bags	1.39	manual adjustment	1.27
supplementary	1.39	seat belts	1.37	manual backrest rake adjustment	1.28
Retractable roof	1.14	seats	1.27	manual forward and rearward	
safe operating temperatures	1.14	Sealant - tyre	5.12	adjustment	1.27
Rev counter	3.2	Seamless Shift Gearbox	2.18	manual height adjustment	1.28
Right-hand display	3.33	gear positions	2.18	racing seat adjustment	1.28
display window	3.33	gearshift paddles	2.21	safety	1.27
fuel level	3.35	kickdown	2.19	Secondary fuse box	5.21
gear position indicator	3.33	mode	2.19	fuses	5.21
handling and powertrain display	3.33	pre-cog	2.22	Sensor	1.26
oil temperature	3.34	Seat belt warning light	1.39	interior motion	1.26
overview	2.5	Seat belts	1.37	Sensors	2.14
water temperature	3.35	force limiters	1.38	parking	2.14
Roof	1.14	safety	1.37	Service and Warranty	4.20
closing	1.16	tensioners	1.38	Service products	6.9
opening	1.15	wearing	1.38	Setting up warning triangle	5.12
Running in	2.48	Seats	1.27	Settings - individual unlock	1.8
		backrest - electric	1.30	Side head air bags	1.40
		backrest - manual	1.28	Sidelamps	1.50
		electric adjustment	1.29	Snow chains	2.53
		electric backrest rake adjustment	1.30	Specification - engine oil	6.9
		electric forward and rearward		Speedometer	3.2
		adjustment	1.29	Speeds - in gear	6.5
		electric height adjustment	1.30	Spoiler	2.36
		electric seat adjustment	1.29	START/STOP button	2.3
		electric seat and mirror memory	1.31		

S

Safety	1.37
air bag system modification	1.40
air bags	1.39
air bags Out Of Position (OOP)	1.43
battery	5.14
car washes	1.4

Starting and driving	2.2	Switch - lighting	1.49	Traction control system	2.34
foot brake	2.10	Switching air conditioning on/off	4.5	Triangle - warning	5.11
gear positions	2.6	Switching on the ignition	2.3	Trip	3.21
gearshift paddles	2.7	Symbols	5	Turning circle	6.8
instruments and warning lights	2.3			Tyres	5.33
main instruments	2.4	T		asymmetric	5.33
parking brake	2.8	Tachometer	3.2	inspecting	5.34
starting the engine	2.10	Technical data	6.4	markings	5.33
switching on the ignition	2.3	engine	6.4	monitoring system	2.40
warning lights	2.5	Technical glossary	6.11	pressure monitoring	2.40
Starting the engine	2.10	Temperature - air conditioning	4.7	pressures	5.35, 6.8
discharged key fob battery	5.26	Temperature display	3.6	repair kit	5.36
Steering column	1.34	Tensioners - seat belt	1.38	sealant	5.12
Steering wheel	1.34	Tonneau cover	1.19	summer	6.8
electrical adjustment	1.35	opening and closing	1.19	temperature monitoring	2.42
horn	1.36	Topping-up	5.2	Trofeo R	5.37
manual adjustment	1.34	brake fluid	5.8	winter	6.8
Stopping the engine	2.11	coolant	5.6		
Stowage bags	1.21	engine oil	5.3	U	
installing	1.22	gearbox oil	5.5	Unlocking - discharged battery	5.25
removing and storing	1.23	power steering fluid	5.7	Unlocking and opening the luggage	
Stowage compartment/audio interface	4.19	windscreen washers	5.9	compartment	1.12
Stowage luggage	1.21	Tow-away protection	1.25	Unlocking from inside	1.8
Stowage net	4.17	Towing	5.45	Upper speed limit	2.47
Stowing the key fob	1.4	eye	5.13	setting	2.47
Summer tyres	6.8	Track driving	2.49		
Sun visors	4.19	Tracking system	4.12		
Supplementary Restraint System	1.39				

V

Vehicle dimensions	6.6
Vehicle electrical status	2.2
Vehicle identification number	6.3
Vehicle lift	1.56
operation	1.56
operation and instrument display	3.22
Vehicle lifting points	5.43
Vehicle operating temperatures	6.4
Vehicle speeds	6.5
Vehicle starting	2.10
discharged key fob battery	5.26
Vehicle tracking	4.12
customer service	4.15
Vehicle use	2.48
Vehicle washing	5.39
Vehicle weights	6.7
Vents	4.9
Volumetric alarm	1.26

W

Warning - engine oil level	5.2
Warning - engine oil temperature	5.5
Warning light	
Anti-lock Braking System	2.32
brakes	2.10
engine	2.13
seat belt	1.39
Supplementary Restraint System	1.43
Warning lights	
left-hand side	2.5
right-hand side	2.6
Warning triangle	5.11
Washers	5.9
windscreen	5.9
Washing	5.39
exterior	5.39
wheels	5.40
Water temperature display	3.35
Wearing seat belts	1.38
Weights	6.7
Wheel - steering	1.34
electrical adjustment	1.35
manual adjustment	1.34
Wheel sizes	6.8

Wheels	5.32
inspecting	5.34
interchanging	5.36
Wheels and tyres	5.32
Window demisting	4.9
Windows	4.2
anti-trap protection	4.3
opening and closing	4.2
Windscreen washers	5.9
Windscreen wiper	1.54
rain sensor	1.54
single wipe	1.55
wash/wipe	1.55
Winter driving	2.53
Winter mode	2.28
Winter tyres	6.8
Wiper blade replacement	5.31

